



STS DAY TANK

PACKAGED DAY TANK SYSTEMS

Last revision date: December 17, 2021

For the most up-to-date information for this product and others,
please contact Simplex, Inc. at (800) 637-8603 or visit us
on the web at <http://www.simplexdirect.com>.

Table of Contents

1 WARNINGS AND CAUTIONS	2
Safety Information Symbols	2
Cautions	2
2 NAMEPLATES AND PLACARDS	4
3 INSTALLATION	6
Overview of Use	6
Installation Operation	7
Vent Openings	10
Day Tank Pump Priming Procedure.....	11
4 DAY TANK OPERATION	12
Automatic Operation	13
High Level Fill Disabled	13
Fill Test Pushbutton	14
Low Level Fill Alarm	14
Manual Operation	15
Lamp Test.....	15
Automatic Duplex Pump Controller, Option 345	15
Overflow - Return Tank, Option 383	17
Overflow - Return Pump and Controller Added to the Day Tank, Option 390.....	18
5 MAINTENANCE	19
Each Year	19
After the First Three Years	19
6 TROUBLESHOOTING	20
No Fuel Delivered	20
Insufficient Fuel Delivered.....	20
Rapid Pump Wear	20
Pump Delivers for Short Period and Quits.....	20
Pump Requires too Much Power.....	20
Noisy Operation	21
Pump Requires Frequent Re-Priming.....	21
Motor Does Not Turn or Turns Intermittently	21
Pump Leaks Fuel	21
7 DRAWINGS AND PARTS LIST	22
Abbreviation Index	22
Technical Data.....	23

1 WARNINGS AND CAUTIONS

SAFETY INFORMATION SYMBOLS

The following images indicate important safety information:



This General warning symbol points out important information that, if not followed, could endanger personal safety and/or property.



This Explosion warning symbol points out potential explosion hazards.



This Fire warning symbol points out potential fire hazards.



This Electrical warning symbol points out potential electrical shock hazards.

CAUTIONS



- Improper operation of this equipment such as neglecting its maintenance or being careless can cause possible injury or death. Permit only responsible and capable persons to install, operate, and/or maintain this equipment.
- Potentially lethal voltages and amperages are present in these machines. Ensure all steps are taken to render the machine safe before attempting to work on the equipment.
- All hardware covered by this manual have dangerous electrical voltages and can cause fatal electrical shock. Avoid contact with bare wires, terminals, connections, etc., on the hardware, if applicable. Ensure all appropriate covers, guards, grounds, and barriers are in place before operating the equipment. If work must be done around an operating unit, stand on an insulated dry surface to reduce shock hazard.
- Do not handle any kind of electrical device while standing in water, while barefoot, or while hands or feet are wet. **DANGEROUS ELECTRICAL SHOCK MAY RESULT.**
- If trained personnel must stand on metal or concrete while installing, servicing, adjusting, or

repairing this equipment, place insulative mats over a dry wooden platform. Work on the equipment only while standing on such insulative mats.

- The National Electrical Code (NEC), Article 250 requires the frame of the equipment to be connected to an approved earth ground and/or grounding rods. This grounding will help prevent dangerous electrical shock that might be caused by a ground fault condition or by static electricity. Never disconnect the ground wire.
- Wire gauge sizes of electrical wiring, cables, and cord sets must be adequate to handle the maximum electrical current (ampacity) to which they will be subjected.
- Before installing or servicing this (and related) equipment, make sure that all power voltage supplies are completely turned off at their source. Failure to do so will result in hazardous and possibly fatal electrical shock.
- In case of accident caused by electric shock, immediately shut down the source of electrical power. If this is not possible, attempt to free the victim from the live conductor. **AVOID DIRECT CONTACT WITH THE VICTIM.** Use a nonconducting implement, such as a dry rope or board, to free the victim from the live conductor. If the victim is unconscious, apply first aid and seek immediate medical attention.
- Never wear jewelry when working on this equipment. Jewelry can conduct electricity resulting in electric shock or may get caught in moving components causing injury.
- Keep a fire extinguisher near the hardware at all times. Do NOT use any carbon tetra-chloride type extinguisher. Its fumes are toxic, and the liquid can deteriorate wiring insulation. Keep the extinguisher properly charged and be familiar with its use. If there are any questions pertaining to fire extinguishers, please consult the local fire department.
- The illustrations in this manual are examples only and may differ from your unit.



2 NAMEPLATES AND PLACARDS

RETURN PUMP MOTOR

PRESS TO TEST ONLY WHEN ARMED (HOLD FOR MANUAL)

RETURN PUMP MOTOR ARMED ABOVE 70%

RETURN PUMP MOTOR RUNNING

UNDER TEST
RETURN PUMP WILL RUN AND PUMP-DOWN TANK TO 70% LEVEL TO REFILL TANK TO NORMAL FULL LEVEL. PRESS TEST PUSHBUTTON ON MAIN CONTROL PANEL.

Level Controller

CONTROL

FILL TEST

AUTO

OFF

MANUAL

STATUS

POWER AVAILABLE

TANK FILLING

NOT IN AUTO

TANK LEAK

FUEL LEVEL

HIGH LEVEL ALARM

TANK FULL

NORMAL OPERATING RANGE

FILL START

LOW LEVEL ALARM

HIGH LEVEL TANK FULL

NORMAL OPERATING RANGE

FILL START

LOW LEVEL

SIMPLEX[®]
(800) 637-8603
www.simplexdirect.com

JOB#

MODEL:

SHORT CIRCUIT
CURRENT RATING: 5 KA
RMS SYMMETRICAL, 600V MAX.
ENCLOSURE: TYPE:

LARGEST MOTOR FLA:

FILL PUMP 1 SUPPLY CIRCUIT:
VOLTAGE: 115 VAC, 1-PH, 60 Hz
FULL LOAD AMPS: A
PUMP CAPACITY: GPM
PUMP MOTOR HP:

CONTROL POWER AND RETURN PUMP 1 SUPPLY CIRCUIT:
VOLTAGE: 115 VAC, 1-PH, 60 Hz
FULL LOAD AMPS: A
PUMP CAPACITY: GPM
PUMP MOTOR HP:

PUMP LIFT 20 FEET MAXIMUM
FLUID VISCOSITY 32-100 SSU

SIMPLEX[®]

FUSE REPLACEMENT CHART

F1: 1AMP, 250VAC
F2: 1AMP, 250VAC
F3: 2AMP, 600VAC, TD
F4: 2AMP, 600VAC, TD

FOR FIELD WIRING USE
COPPER WIRE 60 DEGREE
CENTIGRADE OR BETTER

NOT IN AUTO

PUMP #1 RUNNING

PUMP #2 RUNNING

DUPLIX

ALT. BOTH

PUMP #1

OFF MAN AUTO

PUMP #2

OFF MAN AUTO

Level Controller

CONTROL

FILL TEST

AUTO

OFF

MANUAL

STATUS

POWER AVAILABLE

TANK FILLING

NOT IN AUTO

TANK LEAK

FUEL LEVEL

HIGH LEVEL ALARM

TANK FULL

NORMAL OPERATING RANGE

FILL START

LOW LEVEL ALARM

HIGH LEVEL TANK FULL

NORMAL OPERATING RANGE

FILL START

LOW LEVEL

SIMPLEX[®]
(800) 637-8603
www.simplexdirect.com

JOB#

MODEL:

SHORT CIRCUIT
CURRENT RATING: 5 KA
RMS SYMMETRICAL, 600V MAX.
ENCLOSURE: TYPE: OFF

LARGEST MOTOR FLA:

FILL PUMP 1 SUPPLY CIRCUIT:
VOLTAGE: 115 VAC, 1-PH, 60 Hz
FULL LOAD AMPS: A
PUMP CAPACITY: GPM
PUMP MOTOR HP:

FILL PUMP 2 SUPPLY CIRCUIT:
VOLTAGE: 115 VAC, 1-PH, 60 Hz
FULL LOAD AMPS: A
PUMP CAPACITY: GPM
PUMP MOTOR HP:

CONTROL POWER SUPPLY CIRCUIT:
VOLTAGE: 115 VAC, 1-PH, 60 Hz
FULL LOAD AMPS: A

PUMP LIFT 20 FEET MAXIMUM
FLUID VISCOSITY 32-100 SSU

SIMPLEX[®]

FUSE REPLACEMENT CHART

F1: 1AMP, 250VAC
F2: 1AMP, 250VAC
F3: 2AMP, 600VAC, TD
F4: 2AMP, 600VAC, TD
F5: 2AMP, 600VAC, TD

FOR FIELD WIRING USE
COPPER WIRE 60 DEGREE
CENTIGRADE OR BETTER

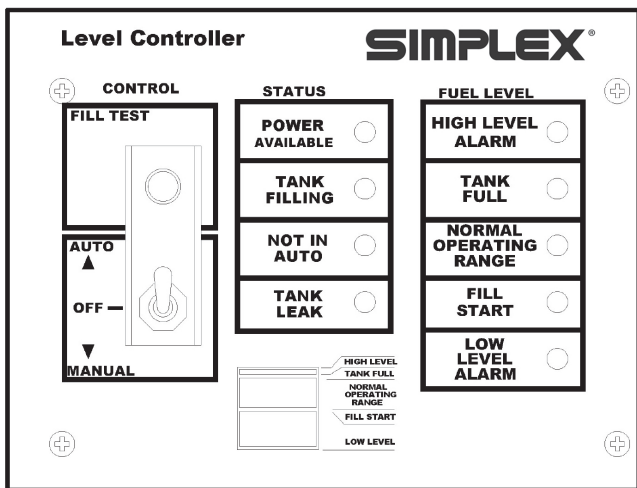

SIMPLEX®
(800) 637-8603
www.simplexdirect.com

JOB#

MODEL:

SHORT CIRCUIT CURRENT RATING: 5 kA
RMS SYMMETRICAL, 600V MAX.

ENCLOSURE: TYPE

LARGEST MOTOR FLA:

CONTROL POWER / FILL PUMP CIRCUIT:
VOLTAGE: VAC, -PH, Hz

FULL LOAD AMPS: A

PUMP CAPACITY: GPM

PUMP MOTOR HP:

PUMP LIFT 20 FEET MAXIMUM
FLUID VISCOSITY 32-100 SSU

SIMPLEX®

FUSE REPLACEMENT CHART

F1:	1AMP, 250VAC
F2:	1AMP, 250VAC
F3:	2AMP, 600VAC, TD
F4:	2AMP, 600VAC, TD
F5:	2AMP, 600VAC, TD

FOR FIELD WIRING USE
COPPER WIRE 60 DEGREE
CENTIGRADE OR BETTER

3 INSTALLATION

OVERVIEW OF USE

Location of the Day Tank is of prime importance and should be done by trained personnel. It is one of the most critical factors involved in reliable and safe operation. The Day Tank must be positioned and installed according to the main fuel storage tank and engine location. In general, locate the Day Tank as close to the engine as possible consistent with applicable local and national plumbing and electrical codes. Always position the Day Tank so that the highest fuel level in the tank is lower than the engine injectors. The Day Tank must be located not farther than 200' from the main fuel tank. The Day Tank must not be more than 18' higher than the lowest fuel level in the main fuel tank. Never locate the Day Tank in a confined space without consideration for accidental fuel spillage and use a rupture basin when necessary. Never locate the Day Tank near a surface or object which may be adversely affected by fuel oil. Never locate a Day Tank system above a residential living space.

If you have any questions regarding Day Tank installation, call Simplex service at (800) 637-8603 (24 hrs.).

See dimensional drawing for port sizes. All plumbing to and from the Day Tank should be black iron pipe or copper tubing. All plumbing connections at the tank should be made with pipe unions to facilitate installation and service. Special attention must be given to pump suction pipe connections to avoid possible air leaks and subsequent loss of pump prime. Never allow the Day Tank pump to run "dry" as immediate pump damage will occur. Before applying power to the pump/motor be sure all fuel connections have been made and tightened and all holes are plugged. Option 010 or 015, auxiliary hand pump, is recommended for installation on all Day Tanks with motor-pumps. The hand pump is used for initial priming of the fuel line from the main tank and as a back up to the motor pump.

INSTALLATION OPERATION

⚠ WARNING ⚠

The overflow connection is a mandatory connection!

⚠ WARNING ⚠

Always connect the Day Tank to an earth ground before operating the Day Tank. Electrical shock can cause personal injury or death!

1. Remove the Day Tank top. Check all visible hardware for tightness. Attach the Vent Pipe. This is an NPT internal connection. The vent pipe allows equalization of internal Day Tank pressure. **DO NOT INSTALL A VALVE IN THE VENT LINE!** Venting provides pressure relief in case of overflow, rapid expansion, or gasification of contents in the event of fire. The Day Tank may become permanently distorted at pressures above 5PSI (10 and 25 gallon) and 3PSI (50–400 gallon) and may rupture at pressures above the maximum withstand pressure of 25PSI (10 and 25 gallon) and 15PSI (50–400 gallon). Day Tank operation without a vent pipe is strictly not recommended. The vent pipe should be at least 5 feet higher than any other pipe and should terminate outdoors. The vent pipe must be installed per local building codes and per NFPA 30 including but not limited to Section 19.5.3. There should be no low portions or sags in the vent pipe which can trap liquid. The end of the pipe should be fitted with a 180° weather protected vent cap to shed water and should be screened to keep out pests, leaves, etc.

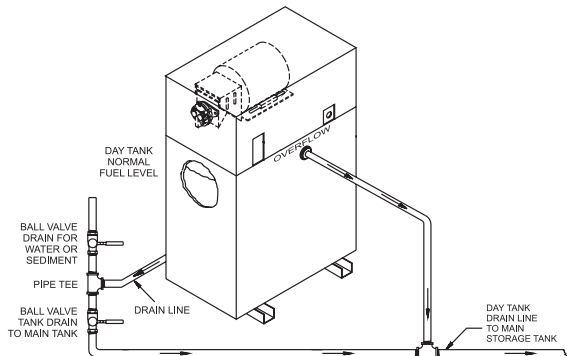

2. Attach the Overflow Pipe. This is an NPT internal connection. Simplex recommends the configuration shown in the illustration above. The overflow pipe runs from the Day Tank back to the main storage tank and allows for draining of the tank should it become overfilled. This pipe should be sized at least twice the diameter of the pump fill pipe (minimum 1" I.D. for 10 and 25 gallons; minimum 2" I.D. for 50–500 gallon). If the tank becomes overfilled and the overflow line is not

⚠ WARNING ⚠

Risk of electric shock! More than one Disconnect Switch may be required to de-energize the equipment before servicing.

⚠ WARNING ⚠

Verify the Main Disconnect Switch and pump Auto-Off-Run switches are in the Off position before performing installation procedure.

connected or is obstructed the tank will distort and possibly rupture. In installations where the main fuel tank is above ground the overflow pipe should be connected to an Overflow Pump (Option #390 Recommended). **DO NOT INSTALL A VALVE IN THE OVERFLOW LINE!**

3. Attach the Day Tank Intake Line (fill pipe) from the main fuel tank to the pump inlet. This is an NPT internal connection. Use black pipe with a union and size per the dimensional drawing. Optional fuel strainer (Option 060) with #60 mesh is recommended.
4. Attach the Engine Supply Line. This is an NPT external connection. Use black pipe with a union and size per the dimensional drawing in this manual. Attach the Engine Return Line. This is an NPT internal connection. Use black pipe with a union and size per the dimensional drawing.
5. Attach the Engine Return Line. This is a NPT internal connection. Use black pipe with a union and size per the dimensional drawing.
6. **WARNING! Verify the Day Tank mode selector switch is in the “Off” position.** Supply a 115-1-60, 15A, circuit breaker protected circuit from a reliable power bus to the control power terminal board (TB”PS”) at terminals 1 and 2. **GROUND THE DAY TANK!** Secure the conduit end to the left side of the cover at the holes provided. Replace the cover.

IMPORTANT NOTE!! The system shall be for use with fuel oil as described by NFPA321, “Basic Classification of Flammable and Combustible Liquids.” As defined by this standard, the fuel supply system shall be for use with “combustible liquids,” those having a flash point at or above 100°F and further defined as Class II or Class III liquids. In no case shall a liquids having a flash point less than 100°F be used. In every case, the system shall not be used or applied at a temperature in excess of the flash point of the contents. Electrical equipment used in the system shall be in accordance with NFPA30, section 5-7, wherein it states “For areas where Class II or Class III liquids only are stored or handled at a temperature below their flash points, the electrical equipment may be installed in accordance with provisions of NFPA70, National Code, for ordinary locations...”

- The pump has been pre-lubricated with heavy oil prior to shipment. Prime the system by using the hand pump (Option 010 or 015) to transfer fuel from the main tank to the Day Tank. If the Day Tank is not equipped with a hand pump, remove the tank inlet priming tee plug and fill the entire inlet line with fuel. Replace the tee plug. Energize the Day Tank pump/motor by placing the Day Tank mode selector switch in the automatic position. Ensure that fuel is exiting the pump by watching the clear pump outlet tubing. If not, repeat this procedure and prime the pump also at the pump priming tee. Make sure all unused Day Tank holes are plugged, all pipe connections are secure and no leaks are present. The Day Tank is now ready for unattended automatic operation. If the Day Tank has been stored for extended periods of time pre-lube the pump with oil at the pump priming tee.

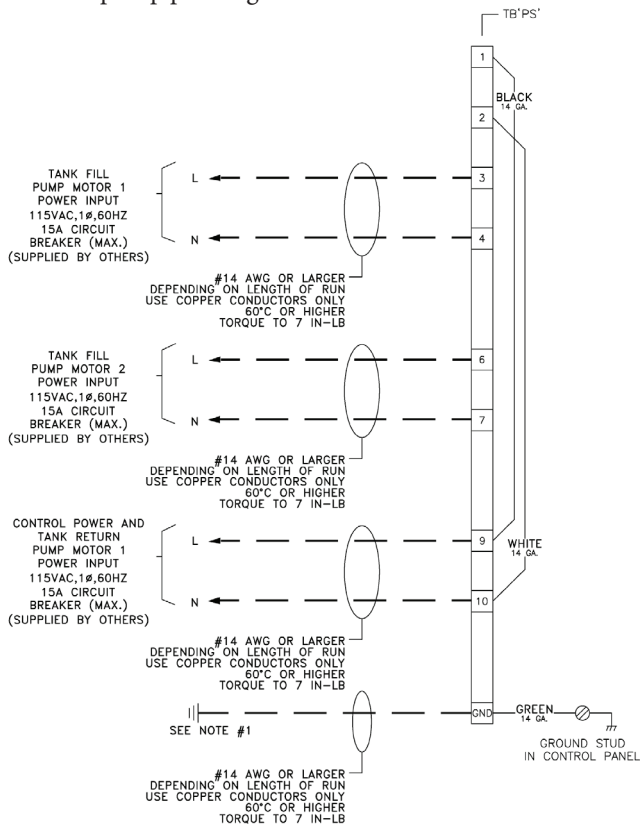

VENT OPENINGS

Each tank and each compartment of a compartment tank shall have provision for both normal and emergency venting. A vent opening shall be in addition to the filling and withdrawal openings. A vent opening that provides both emergency and normal venting shall have a capacity not less than that specified in the Venting Capacity Table below. The wetted area of a tank is calculated on the basis of 75% of the total exposed area.

VENTING CAPACITY		
WETTED SURFACE, SQUARE FEET ^{b,c}	VENTING CAPACITY, CUBIC FEET PER HOUR ^{d,e}	MINIMUM OPENING, NOMINAL PIPE SIZE, INCHES ^f
20	21,100	2
30	31,600	2
40	42,100	3
50	52,700	3
60	63,200	3
70	73,700	4
80	84,200	4
90	94,800	4
100	105,000	4
120	126,000	5
140	147,000	5
160	168,000	5
180	190,000	5
200	211,000	6
250	239,000	6
300	265,000	6
350	288,000	8
400	312,000	8
500	354,000	8
600	392,000	8
700	428,000	8
800	462,000	8
900	493,000	8
1000	524,000	10
1200	557,000	10
1400	587,000	10
1600	614,000	10
1800	639,000	10
2000	662,000	10
2400	704,000	10
2800 and over	742,000	10

a At 14.7 psia and 60°F (101.4kPa and 16°C)

b Interpolate for intermediate values

c For SI units, $m^2 = ft^2 / 0.09$

d These values taken from NFPA 30

e For SI units, $m^3/s = ft^3/hr \times 0.03$

f These pipe sizes apply only to open vent pipes of the specified diameter not more than 12 inches (0.3m) long and a pressure tank of not more than 2.5 psig (17.1kPa). If tank is to be equipped with venting device or flame arrestor, the vent opening is to accommodate the venting device or flame arrestor sized in accordance with column 2 of this table.

DAY TANK PUMP PRIMING PROCEDURE

⚠ WARNING ⚠

Attempting to pre-prime the Day Tank delivery system by running the pump will cause serious damage to the pump!

⚠ WARNING ⚠

This is an industrial product, not a consumer product. It must be specified, installed, operated and maintained by individuals equipped with the appropriate training and skills.

The Day Tank pump is shipped from the factory pre-primed with SAE 30 oil. On initial start-up the pump must be manually pre-primed. **Do not prime the system by running the pump motor!** Normally it is not necessary to fill the supply line with fuel to prime the pump.

1. Fill the line from the check valve to the pump with fuel oil or lube oil. Energize the pump/motor and observe fuel flowing through the clear flex hose. Allow the pipe to drain about halfway, then hold your hand on the top of the pipe to temporarily seal the open tee. The oil drawn into the pump will act to seal the pump and allow a large vacuum to be generated. Repeat as required until line is primed.

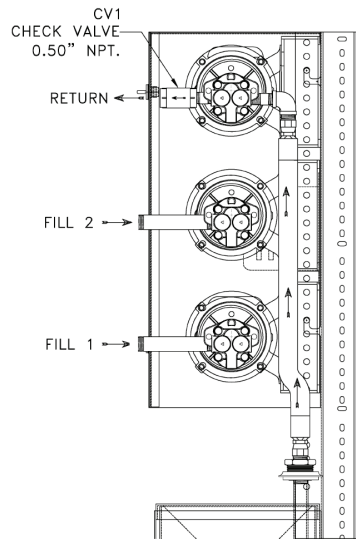
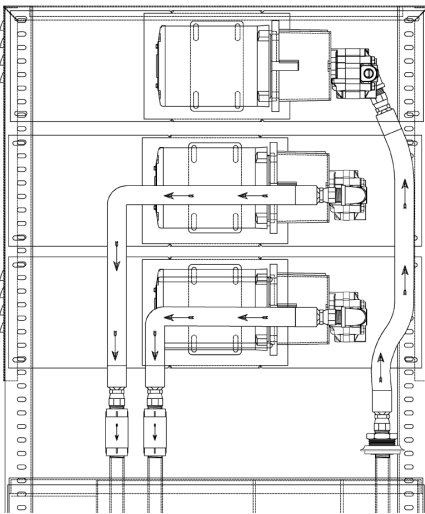

4 DAY TANK OPERATION

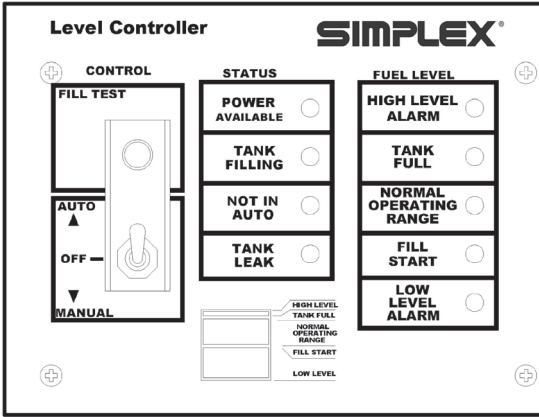

The control nameplate consists of a durable, fuel oil resistant, Lexan membrane which contains the Day Tank control pushbutton, switch and status indicators. The control panel contains a Fill Test pushbutton (hold to test L.E.D. lamps), a three position Day Tank Auto-Off-Manual switch, and the following L.E.D. lamps: Power Available,

Tank Filling, Tank Leak, Not In Auto (blinking), High Level Alarm, Tank Full, Normal Operating Range, Fill Start, and Low Level Alarm. Day Tank operation is represented by the diagram in the lower center of the nameplate.

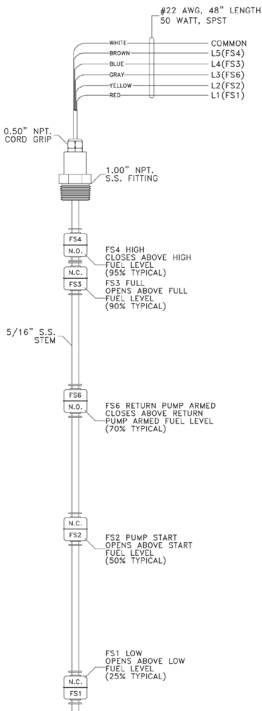

The Day Tank control circuitry contains the following serviceable components: motor starting contactor, and control fuses. Control fuses are 2A, 250VAC, ABC type, and the standard motor starting contactor is a double pole, 24VDC coil, rated at 20A. The prime controller in the Day Tank is the printed circuit board. The Day Tank printed circuit board is powered by a fused internal 24VDC, 2A, power supply. The printed circuit board utilizes 24VDC components to analyze the fuel level data it receives from the four Day Tank fuel level sensors. The four fuel level sensors together with the sensor mounting plate comprise the fuel level sensor assembly. When 120VAC, single phase, 60Hz control power is supplied to the Day Tank control system the Power Available L.E.D. is illuminated. See Parts Legend Drawing for specific components used.

During automatic operation, the printed circuit board energizes and de-energizes control relays, the motor starter contactor, and the pump/motor to automatically refill the Day Tank as fuel is consumed

by the prime mover. Dry contacts for Low Fuel Level, High Fuel Level, Leak Alarm, and Not In Auto relays are wired to terminals 1-12 of terminal block TB'A' for customer use. The customer may utilize these contacts to annunciate low fuel level and high fuel level. Contacts are rated at the following specifications: 5A@30VDC, 5A@125VAC.

AUTOMATIC OPERATION

WARNING

Day Tank operation is automatic and the day tank motor may start at any time! After a motor thermal overload reset the motor may restart at any time!

WARNING

Never use a Day Tank to transfer or store Class I, flammable, or liquids with a flash point less than 100°F. Ignition of fuel can cause severe personal injury or death! Day Tanks are approved for use with combustible liquids (Class II or Class III liquids) with a flash point at or above 100°F provided they are stored below the flash point ambient temperature!

The Day Tank operator selects the Day Tank operating mode via the three position Day Tank mode selector toggle switch. The operator may choose Automatic, Manual, or Off. To alert the Day Tank operator, the red Not In Auto lamp flashes continuously when the Day Tank mode selector switch is not in the Auto position. This is the only flashing lamp on the control panel. Normally the mode selector switch is left in the automatic position. After initial Day Tank installation, priming, and fill, the controller printed circuit board will energize and de-energize the Day Tank pump/motor as determined by the opening and closing of the fuel level sensors (25%-FS1, 50%-FS2, 90%-FS3, 95%-FS4). As the Day Tank continues to fill and the fuel level reaches 50% capacity the Normal Operating Range L.E.D. will be illuminated. The Day Tank pump/motor will de-energize when the fuel level reaches 90% (the Normal Operating Range L.E.D. is extinguished and the Tank Full L.E.D. is illuminated). During normal operation fuel is consumed by the prime mover and the Day Tank cycles between 50 and 90% capacity, energizing and de-energizing the motor/pump as necessary. If the pump/motor continues to run past the 90% capacity level, normally open fuel level sensor FS4 will close when 95% capacity is reached. At this point the High Level Alarm L.E.D. will be illuminated and the pump will de-energize.

HIGH LEVEL FILL DISABLED

A High Level alarm causes the Day Tank to enter a new mode of operation dependent on the position of the mode selector switch. Regardless of the operation mode, High Level indicates that fuel level has reached or exceeded 95% capacity. The pump/motor is de-energized and will remain locked out until the Day Tank fuel level is decreased to 90% capacity or less. The High Level L.E.D. will remain illuminated until reset by the operator regardless of Day Tank fuel level. If a High Level Alarm condition occurs

and the Day Tank fuel level is reduced to normal levels the High Level L.E.D. will remain illuminated until it is reset by the operator. The operator must place the Day Tank mode selector switch in the Off position and then return it to the Manual or Automatic position to reset the High Level failure. When High Level is initiated while in Automatic Mode the Day Tank will continue to operate normally and cycle from 50% to 90% but the High Level L.E.D. will remain illuminated until it is reset. When the High Level mode is initiated while in Manual Mode the Day Tank pump/motor will cycle between the 90% and 95% levels as determined by fuel level sensors FS3 and FS4. After the condition is corrected and the control circuitry is returned to Auto the pump/motor will resume normal operation and cycle between 50% and 90%. Fuel level sensors FS1-FS3 (Low Fuel Level Alarm, Fill Start, and Tank Full, respectively) have normally closed contacts. FS4 (High Level Alarm) is the only fuel level sensor with normally open contacts.

FILL TEST PUSHBUTTON

The Fill Test pushbutton is a momentary type. It may be used to provide a quick verification of overall pump/motor/fuel level sensor operation when the system is in the Auto mode. When the mode selector switch is placed in the Off position, the Fill Test pushbutton is disabled. When the mode selector switch is in the Automatic position, the Fill Test pushbutton is enabled.

The operator may energize the pump/motor with the Test Fill pushbutton to test and cycle the Day Tank through the specified capacity range. When the pump is operated by continuously holding the Fill Test pushbutton the pump/motor will continue to run past the normal stop level until 95% capacity is reached, at which point the pump/motor is de-energized and locked out by fuel level sensor FS4. The High Level L.E.D. will be illuminated and the High Level alarm relay will be energized. Contact rated 5A @ 30 VDC, 5A @ 125VAC maximum.

LOW LEVEL FILL ALARM

During normal operation, the pump/motor is energized and the Fill Start L.E.D. is illuminated when the Day Tank fuel level reaches 50% capacity. If the pump/motor does not energize a low fuel level alarm

will be initiated when Day Tank fuel capacity reaches the 25% level. The low fuel alarm relay LFR energizes, the Low Level Alarm L.E.D. is illuminated, and LFR dry contacts close. The Day Tank user may utilize these contacts to sound an alarm horn or provide an input to a remote annunciator. Contacts are 5A @ 30VDC, 5A @ 125VAC maximum.

MANUAL OPERATION

For manual (continuous run) operation, the Day Tank operator must place the Day Tank mode selector toggle switch in the Manual position. Manual operation allows the Day Tank operator to energize and run continuously the pump/motor independent of fuel level sensors FS1-FS3. During manual operation the control panel L.E.D. lamps will continue to annunciate fuel level to the Day Tank operator. The Day Tank will continue to fill until 95% capacity is reached at which time the High Level mode will be initiated. The Day Tank pump/motor will be de-energized and locked out until Day Tank fuel level is reduced to 90% capacity and fuel level sensor FS3 changes state. Until the alarm condition is corrected and the control circuitry is reset to Auto the Day Tank pump/motor will continue to cycle between the 90% and 95% levels. Upon return to Auto, the control circuitry is reset and the pump/motor will resume normal operation and cycle between 50% and 90%.

LAMP TEST

The momentary Fill Test pushbutton is also used to test L.E.D. lamps on the control board. To use this feature, press and hold the Fill Test pushbutton to illuminate the L.E.D. lamps. If desired, the lamps may be tested without filling the tank further by placing the mode switch in the “Off” position before pressing the Fill Test pushbutton.

AUTOMATIC DUPLEX PUMP CONTROLLER, OPTION 345

Duplex pump options are used to increase the reliability of a day tank system through the addition of a second, back-up pump and level control. In a duplex system, one pump is designated the “lead” pump and the other is the “lag” pump. The lead pump automatically refills the day tank over the tank’s normal operating range of 50% to full. Normally, once the tank has been initially filled, the fuel level should never drop below 50%. Less than 50% is indicative of either a failure of the lead pump or consumption in excess of pump capacity. The lag pump and its separate

level controller, acting as a backup senses a drop in fuel level at 25% and starts the lag pump, which then continues to run, along with the lead pump, until the tank is full. Multi-function duplex pump controller system providing selectable operating modes, including:

- Automatic lead pump alternating with automatic lag pump back-up
- Automatic twin pump operation (both pumps run simultaneously) automatic level control back-up
- Manual operation

Basic System includes the following:

- All controller features
- Manual off Auto Switch (1 per pump)
- Pump running indicators for each pump
- Two pumps, each with check valves

Operation: With the Duplex switch in the Alternate position, Pump 1 will start at 50% and shut off at the 90% level. For utilization of both Pump 1 and Pump 2 simultaneously, switch to Both positions. In this position Pump 1 and Pump 2 will start at the 50% level and shut off at the 90% level.

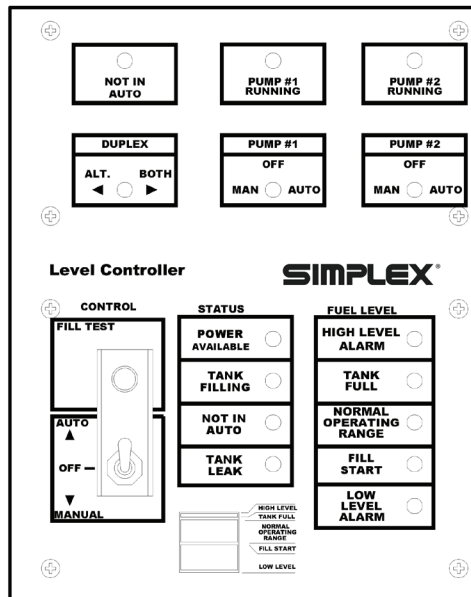

⚠ WARNING ⚠

Day Tank operation is automatic and the day tank motor may start at any time! After a motor thermal overload reset the motor may restart at any time!

When the Mode Selector switch is in the Manual position all floatswitches, except the high fuel level floatswitch are over-riden, and either position (Alternate or Both) may be selected. The pumps will continue to run until Switch #1 is returned to the Off or Auto position or if a high fuel condition occurs. For standard duplex operation, the Duplex switch should be in the Alternate position and Mode Selector switch should be in the Auto position. Pump #1 will then start at 50% level and stop at the 90% level. The next time fuel drops back to the 50% level Pump #2 will start and then stop at the 90% level. Continuing operation alternates between Pump #1 and Pump #2. When the fuel drops to the 25% level, both pumps will run simultaneously until the fuel level returns to the 90% fuel level.

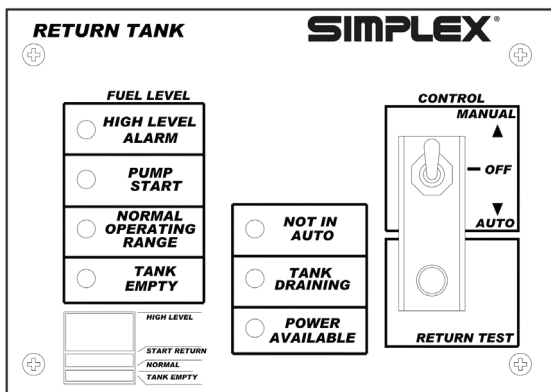

Operation: The control switch should normally be in the Auto position and the Power Available L.E.D. should be illuminated. The level controller is set to pump the tank to virtually empty. Therefore, normally the tank is empty and the Tank Empty L.E.D. is illuminated. If the adjacent Day Tank should overflow and

OVERFLOW - RETURN TANK, OPTION 383

overflow, oil will flow from the overflow line of the Day Tank to the inlet port of the overflow-return tank. Above empty level, float switch FS3 will close. At 20% level in the overflow-return tank, float switch FS2 will close, activating the overflow-return pump which is installed on the tank. The Pump Start L.E.D. will illuminate and the tank will be pumped-down to empty. At empty level, float switch FS3 will open and stop the pump. If the level in the overflow-return tank should continue to rise above the pump start level, float switch FS1 will close at the 30% level activating the “high fuel level” alarm indicator and remote signal contacts.

OVERFLOW - RETURN PUMP AND CONTROLLER ADDED TO THE DAY TANK, OPTION 390

Normally the Day Tank operates automatically to control the fuel level between the 50% and normal full level, 90%. An overflow can occur if the control switch is left in the Manual position, if there is a leak in a control valve permitting gravity or siphon flow of oil into the tank, or if there is a control failure. In the event of an overflow, float switch FS4 will close,

activating the High Level Alarm L.E.D. lamp on the control panel. In addition, the fill pump will be disabled. The tank should not fill above this point, which is 95%. With the addition of option 390, the overflow-return pump will be activated by the overflow alarm circuit and will operate as described below.

Above 70% level, float switch closes and arms the overflow-return controller, illuminating the “overflow return armed” indicator and enabling the overflow pump test push-button. Upon activation of the overflow alarm by float switch FS4, as described above, the over flow pump contactor will be energized, and the overflow

pump will run. The contactor is latched-in via 70% level float switch and the tank will be pumped down to the 70% level. This is intermediate in the normal operating range of 50% to full and the tank should remain at this level; the refill pump will not start until the tank reaches the 50% level. As the overflow pump is running, the “pump running” L.E.D. will be illuminated.

To test the overflow-return pump, press the Test pushbutton. This pushbutton is armed only above the 70% level, when the L.E.D. is illuminated. The overflow pump will pump-down the tank to the 70% level. If desired, the tank can be refilled to normal full by pressing the test pushbutton on the control panel.

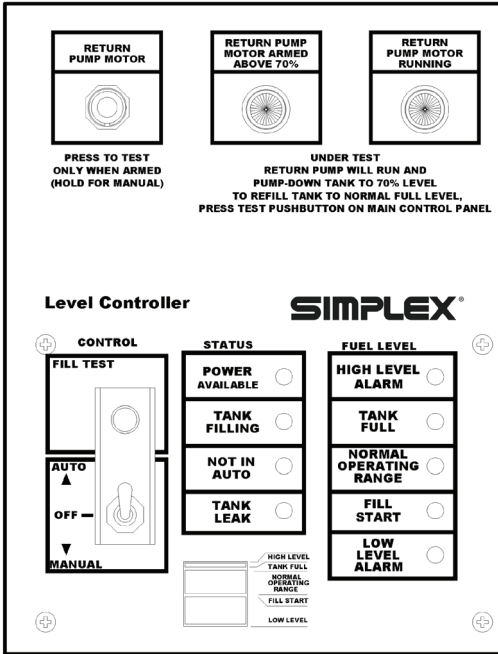

5 MAINTENANCE

The Simplex Day Tank has been designed to require minimum maintenance. All components have been chosen for a long, reliable life. The Day Tank is constantly lubricated by the diesel fuel it transfers. Inspect this tank at least once every year for damage, leakage, or rust on both inside and outside the tank. Promptly repair or replace any significantly damaged or deteriorated Day Tank. Two basic intervals of maintenance are required: each year and after the first 3 years.

EACH YEAR

WARNING

Repairs or alterations of this day tank without written approval from Simplex may void the warranty and incur liability for anyone making such repairs or alterations. Alterations may result in severe personal injury or death due to electrical shock, fire or explosion.

If you have any questions regarding Day Tank maintenance, call Simplex service at (800) 637-8603 (24 hrs.).

1. Water and sediment should be drained from the tank each year. If normal engine/generator testing does not consume one tank full of fuel each year the tank should be drained and refilled with fresh fuel.
2. Examine the interior of the Day Tank. The port is shown in the dimensional drawing. Using an inspection lamp examine all internal Day Tank components.
3. Press the Test Fill pushbutton and observe pump and motor performance.
4. Inspect pump/motor alignment and wear. Inspect the pump for leaks.
5. Re-tighten hose clamps at pump/hose connections. Re-tighten the pump bracket, motor bracket, and pump/motor coupler hardware.
6. Inspect all plumbing connections for leaks. Test all options and fuel level alarms for proper operation.
7. Re-tighten all electrical connections.

AFTER THE FIRST THREE YEARS

After three years of normal use re-oil the Day Tank motor with 10 drops of 5W30 or 10W oil. Do not over oil the motor.

6 TROUBLESHOOTING

NO FUEL DELIVERED

1. Pump not primed.
2. Lift is too high.
3. Rotation direction incorrect.
4. Check valve installed backwards.

INSUFFICIENT FUEL DELIVERED

1. Air leak at inlet.
2. Defective solenoid valve or check valve.
3. Lift too high.
4. Pump worn.
5. Inoperative foot valve.
6. Piping improperly installed.
7. Fuel strainer plugged.

RAPID PUMP WEAR

1. Dirt or grit in fuel.
2. Pipe strain on pump causing bind.
3. Worn pump/motor coupler.
4. Pump has been run dry or with insufficient fuel.

PUMP DELIVERS FOR SHORT PERIOD AND QUILTS

1. Leak at inlet.
2. End of inlet not deep enough.
3. Air or gas in fuel.
4. Supply exhausted.
5. Vaporization of fuel at inlet.
6. Air or gas in inlet line.
7. Sand or abrasives in fuel.

PUMP REQUIRES TOO MUCH POWER

1. Air in plumbing lines.
2. Liquid heavy or too viscous.
3. Bent pump shaft, binding rotating element.
4. Misalignment of pump/motor coupler.

**NOISY
OPERATION**

1. Insufficient fuel supply.
2. Air leaks in the inlet pipe.
3. Air or gas at the inlet connection.
4. Pump and motor out of alignment.
5. Worn out spider coupling.
6. Pump coupler out of balance.

**PUMP REQUIRES
FREQUENT
RE-PRIMING**

1. Inoperative foot valve.
2. Inoperative check valve.
3. Inoperative solenoid valve.
4. Pump cavitation.
5. Plumbing air leaks.
6. Lift too high.
7. Pump seals leaking.

**MOTOR DOES NOT
TURN OR TURNS
INTERMITTENTLY**

1. Control power not available.
2. Motor thermal overload condition.
3. Pump failed and seized.
4. Motor failure.

**PUMP LEAKS
FUEL**

1. Loose pump plumbing fittings.
2. Worn pump shaft seal.
3. Pump pressure relief valve failure.
4. Fuel leak elsewhere running towards pump area.
5. Excessive head from overhead storage tank.
6. Worn pump O-rings.

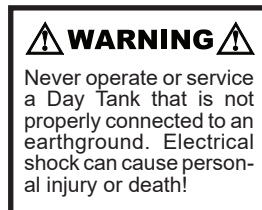

7 DRAWINGS AND PARTS LIST

The drawings included with this manual are the most accurate source of part numbers for your Fuel Supply System. When ordering replacement parts always consult the Parts Legend. When contacting the Simplex Service Department always have your sales order number and drawing number ready for reference. The Job Number and the Drawing Numbers are located on each drawing legend.

ABBREVIATION INDEX

Listed below are abbreviations of terms found on Fuel Supply Systems. When following a drawing utilize this guide to define abbreviated system and component names. As this is a master list, drawings and text pertaining to your equipment may not contain all these terms.

AC -Alternating Current	N.C. -Normally Closed
AHR -Alarm Horn Relay	NEC -National Electric Code
AR -Alarm Horn	NEMA -National Electric Manufacturers Association
BPRV -Back Pressure Regulating Valve	NFPA -National Fire Protection Association
BRK -Motor/Pump Bracket	N.O. -Normally Open
BV -Ball Valve	NP -Nameplate
C -Contactor	NPT -National Pipe Thread
CB -Circuit Breaker	O.D. -Outside Diameter
CSR -Check Strainer Relay	OLR -Over Load Relay
CV -Check Valve	OPT -Option
DC -Direct Current	PCB -Printed Circuit Board
DPDT -Double Pole Double Throw	PCRX -Pump Control Relays
F -Fuse	PG -Pressure Gauge
FLS -Flowswitch	PLR -Pipe Leak Relay
FS -Floatswitch	PRV -Pressure Relief Valve
FSR -Simplex Fuel Strainer	PS -Pressure Switch
GA -Gauge	PSI -Pounds Per Square Inch
GAL -Gallons	PSR -Pressure Switch Relay
GPM -Gallons Per Minute	PRR -Pump Running Relay
HFL -High Fuel Level Relay	SC -Swing Check Valve
HG -Mercury	SOL -Solenoid
HP -Horsepower	TB -Terminal Block
HZ -Hertz	T -Control Transformer
I.D. -Inside Diameter	TDR -Time Delay Relay
JB -Junction Box	TEFC -Totally Enclosed, Fan Cooled
INHG -Inches of Mercury	THR -Tank Heater Control Relay
L -Lamp	TS -Transducer Pressure Switch
L.E.D. -Light Emitting Diode	V -Voltage
LAFFD -Los Angeles Fire Department	VAC -Voltage, Alternating Current
LFF -Loss of Flow Relay	VDC -Voltage, Direct Current
LFL -Low Fuel Level Relay	VG -Vacuum Gauge
LPR -Low Pressure Relay	
MDB -Main Distribution Block	
MDS -Main Disconnect Switch	
MOT -Motor	

TECHNICAL DATA Conversion Factors

PRESSURE AND CONVERSION TABLE		
Feet Water	PSI Oil	PSI Water
1	.35	.43
2	.70	.87
3	1.05	1.3
4	1.4	1.73
5	1.75	2.17
10	3.5	4.33
15	5.2	6.5
20	7.0	8.66
25	8.7	10.8
30	10.5	13.0
35	12.2	15.2
40	14.0	17.3
45	15.7	19.5
50	17.5	21.7
55	19.2	23.9
60	21.0	26.0
65	22.7	28.1
70	24.5	30.5
75	26.2	32.5
80	28.0	34.6
85	29.7	36.8
90	31.5	39.0

1HP = 33,000 ft. lbs. per minute
 1HP = 42.4 btu per minute
 1HP = 0.746 kw/hr (kilowatt hours)

1 U.S. gallon = 231 cubic inches

Pipe Volume varies as the square of the diameter;
 volume in gallons = $0.0034 D^2 L$ where:
 D = inside diameter of pipe in inches;
 L = length in inches

Velocity in feet per sec. = $\frac{0.408 \times \text{flow (gpm)}}{D^2}$

where:

D = inside diameter of pipe in inches

Atmospheric pressure at sea level = 14.7PSI

Atmospheric pressure decreases approximately 0.41PSI for each one thousand feet of elevation up to 23,000 feet.

Pressure (PSI) = feet head x 0.433 x specific gravity

Specific gravity of oil is approximately 0.85.

Thermal expansion of oil is approximately

1 cubic inch per 1 gallon per 10°F rise in temperature.

Hydraulic Formulas

Horsepower = $\frac{\text{GPM} \times \text{PSI}}{1714}$

Torque (lb. in.) = $\frac{\text{CU IN./REV.} \times \text{PSI}}{2}$

Torque (lb. in.) = $\frac{\text{HP} \times 63025}{\text{RPM}}$

Flow (gpm) = $\frac{\text{CU IN./REV} \times \text{RPM}}{231}$

Head and Pressure Equivalents

When converting pressure from feet of water to P.S.I., the specific gravity of the liquid must be considered.

Here are some typical conversion figures:

1 P.S.I.=2.30 feet of water
 (specific gravity 1.0)

1 P.S.I.=2.88 feet of oil
 (specific gravity 0.8)

Pipe Friction- Fuel Oil 2

Pressure Drop in PSI per 100 feet of Pipe and Tube

NOMINAL SIZES - INSIDE DIAMETERS								
Pipe Size, In.	2.0 GPM	7.0 GPM	10.0 GPM	17.0 GPM	23.0 GPM	30. GPM	40.0 GPM	50.0 GPM
.50	2.337	24.65	56.10	148.75	233.75	408.00		
.75		3.61	7.31	21.25	39.53	64.6	93.5	182.75
1.00	.306	2.00	4.16	11.70	19.55	31.87	54.40	80.75
1.25	.10	.51	1.00	2.55	5.10	8.50	14.88	22.10
1.5		.23	.425	1.10	2.04	3.27	5.70	8.33
2.00			.13	.34	.60	.96	3.10	2.38
2.50			.10	1.62	.30	.51	.94	1.275
3.00					.10	1.74	3.06	4.93

NOTE: Pipe sizes shown apply to standard weight schedule 40 pipe.
Tube is standard copper tubing

FLAMMABLE LIQUIDS FLASH POINTS

Excerpts from NFPA 325, "Fire Hazards properties of Flammable Liquids..."

	Flash Points °F(°C)
Diesel Fuel Oil No. 1-D	100 Min. (38) or Legal
Diesel Fuel Oil No. 2-D	125 Min. (52) or Legal
Diesel Fuel Oil No. 4-D	130 Min. (54) or Legal
Fuel Oil No. 1 (Kerosene) (Range Oil) (Coal Oil)	100-162 (43-72)
Fuel Oil No.2	126-204 (52-96)
Fuel Oil No. 4	142-240 (61-116)
Fuel Oil No. 5 Light Fuel Oil No. 5 Heavy	156-336 (69-169) 160-250 (71-121)
Fuel Oil No. 6	150-270 (66-132)
Jet Fuels Jet A and A-1	110-150 (43-66)
Jet Fuels Jet B	-10 to +30 (-23 to -1)
Jet Fuels JP-4	-10 to +30 (-23 to -1)
Jet Fuels JP-5	95-145 (35-63)

Specific Gravity and Viscosity of Oils

Oils	*Specify Gravity At 60°F	Viscosities In SSU at Various Temperatures							
		30°F	60°F	80°F	100°F	130°F	170°F	210°F	250°F
Auto Lubricating S.A.E.-									
10 Max.	.880 to .935	4,400	1,090	430	240	120	66		
20 Max.	.880 to .935	6,900	1,650	750	400	185	90	57	
30 Max.	.880 to .935	13,000	2,700	1,200	580	255	120	66	49
40	.880 to .935	25,000	4,850	2,000	950	380	150	80	55
50	.880 to .935	58,000	10,000	3,700	1,600	600	220	105	67
60	.880 to .935	100,000	15,000	5,300	2,300	800	285	128	76
70	.880 to .935		22,000	7,500	3,100	1,050	342	150	86
10W	.880 to .935								
20W	.880 to .935								
Fuel Oil-									
Diesel No. 2D	.82 to .95	138	70	53.6	45.5	39			
Diesel No. 3D	.82 to .95	390	145	92	65	48	39		
Diesel No. 4D	.82 to .95	4,400	700	280	140	70	44.2		
Diesel No. 5D	.82 to .95	16,500	3,500	1,500	750	320	136	76.5	54
No. 1	.82 to .95				35				
No. 2	.82 to .95	104	56	45.5	40				
No. 3	.82 to .95	126	68	53	45	39			
No. 5A	.82 to .95	1,480	420	215	125	72	48		
No. 5B	.82 to .95	850	600	490	400	315	235	178	141
No. 6	.82 to .95		72,000	21,500	7,800	2,150	590	225	110
Navy Spec.	.989 Max.	3,300	1,100	600	360	190	100	66	50.2
Navy II	1.0 Max.		24,000	8,600	3,500	1,150	370	160	89
Turbine-									
Heavy	.91 Avg.	4,800	1,280	625	350	170	86	57	
Light	.91 Avg.	770	330	208	138	87	58.8		



SIMPLEX, INC.
5300 RISING MOON ROAD
SPRINGFIELD, IL 62711
(800) 637-8603
WWW.SIMPLEXDIRECT.COM