

# Tank Filling Systems

for Petroleum Products



## What is it used for?

Generally used with aboveground storage tanks, although some underground uses as well.

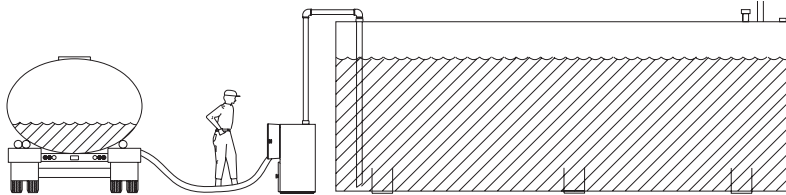

## What is it?

An easy means of filling above ground storage tanks from delivery trucks.

From pumpers...

From gravity trucks...

With manual shutoff

With automatic shutoff

One Tank or Multiple Tanks

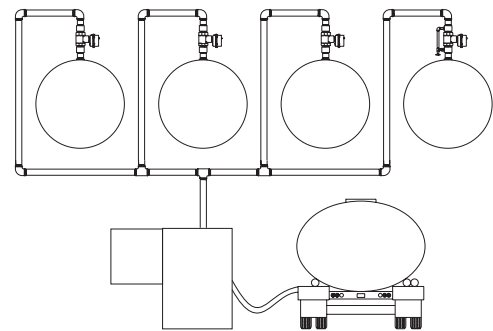

## What kinds of products can I deliver with this system?

Petroleum products and automotive products

- Fuel Oils
- Jet Fuel
- Gasoline
- Lube Oils
- Transmission Fluid
- Hydraulic Oils
- Brake Fluid
- Antifreeze
- Contact Simplex for other products

## Why do I need this Simplex system?

- Easy fill of aboveground storage tanks
- Eliminates ladders, top fill
- Allows use of gravity truck with tall aboveground storage tanks
- Controls and prevents spills
- Provides fill shutoff
- Allows multiple tank filling
- Factory standard, packaged
- Highly engineered
- Economical

### CODES:

FP and FFP: EQ 481  
AFP, SP, CAFP, and MSP: EQ 706  
Non-Explosion Proof Controller:  
UL 508A

TANK FILLING SYSTEMS					
Delivery Truck Type	Shutoff	Product	Number of Tanks	Simplex Model	Page
Pumper	Manual	Class I or Class II Liquids	1	FuelPort	4-5
	Automatic			Automatic FuelPort	6-7
			2 or more		8-9
Gravity	Automatic		1	SmartPump	10, 11, 14
			2 or more		12, 13
<i>Class I Liquid, &lt;100°F Flash Point</i> <i>Class II Liquid, &gt;100°F Flash Point</i>					
CONTROLLERS AND OTHER PRODUCTS					Page
AFC Automatic Fill Controller					15
TC8 Tank Alarm Panel					15

## Selection Guide and Table of Contents



**SmartPump with optional full enclosure. Lockable, with containment basin and hand pump. (Stainless steel cabinet available.)**

## FuelPort



### Description

The Simplex FuelPort is a compact, economical solution for simple filling and spill prevention for aboveground storage tanks. The FuelPort includes all valves and fittings necessary for hose connection from a pumper truck to an above ground storage tank, packaged within a lockable, weatherproof spill containment box.

The FuelPort can be bolted to the tank, hung from the fill pipe, via clamps to a 3" post or mounted on a stand. The FuelPort is suitable for use with fuel oil, gasoline, automotive products, or certain chemicals. An optional vapor recovery adaptor is available.



### Specifications:

Fitting size: 1.5", 2", 3" or 4"  
 Hand pump capacity: 1 gpm  
 Paint: white

Spill containment:  
 Compact FuelPort - 7 gallons  
 Full-Size FuelPort - 20 gallons

Net weight:  
 Compact FuelPort - 129 lbs.  
 Full-Size FuelPort - 250 lbs.

### Fittings: 1.5", 2", 3" or 4"

Inlet to accept:

- Standard fitting: Quick detachable coupling with check valve, shutoff ball valve
- Optional fitting: Buyer specified dry disconnect

Outlet fitting:

- Threaded pipe welded in top panel, 3" NPT threads
- Optional gasoline vapor recovery adaptor

### Includes:

- Weatherproof, lockable box with spill containment
- Tank mounting weld brackets (2)
- FuelPort mounting tabs to accept weld brackets (above) or optional 3" post clamps
- Quick disconnect hose coupling with dust plug
- Hand pump for spill containment, with shutoff and check valve
- Check valve
- Shutoff valve
- Ground stud



FuelPort with optional Flush Wall-mounting Flange

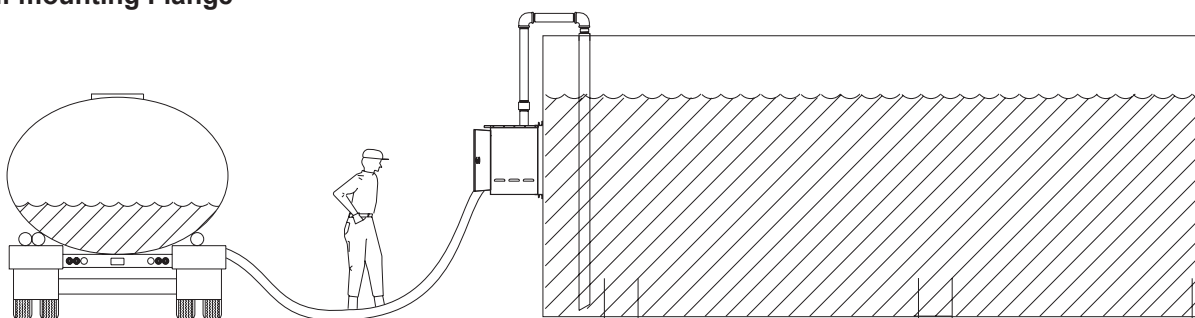

## FuelPort

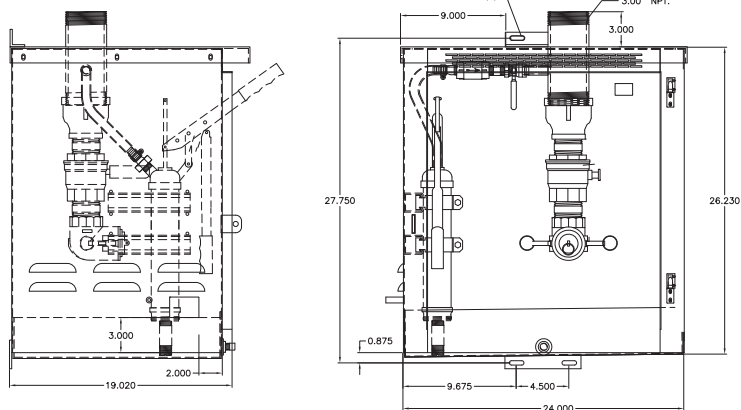

## FuelPort with Flush Wall-Mounting Flange

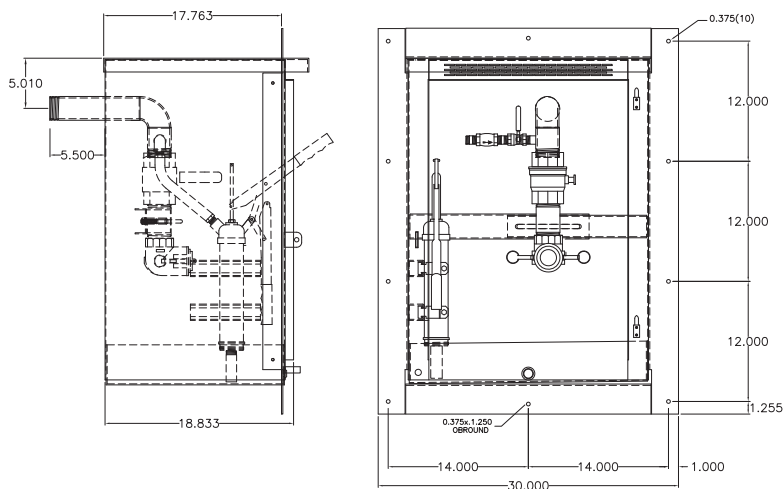

## FuelPort Installation:

- Mount to side of tank using weld brackets (included with FuelPort)

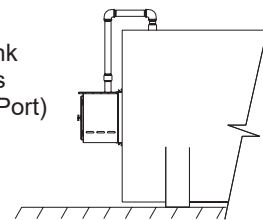

- Clamp to Post (see options list)

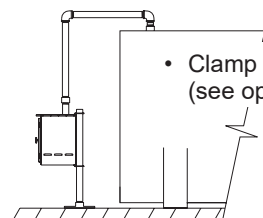

- Hang from Fill Pipe (pipe hanger required)

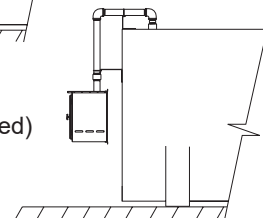

- Mount on Stand (see options list)

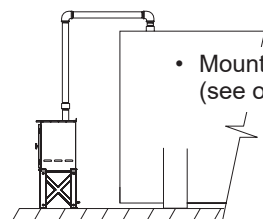

## FuelPort Order Checklist

- Specify fitting size: 1.5", 2", 3" or 4"
- If gasoline use, is vapor recovery required?

### Options:

- Fire rated valves
- Dry disconnect adapter (Full-Size FuelPort only)
- Fuel strainer (Full-Size FuelPort only)
- Hydrostatic level gauge
- Flush wall-mounting flange
- Post assembly with base, 48" high, w clamps
- Post clamps
- Stand
- Fusible link fire valve on outlet
- Stainless steel cabinet construction

## Automatic FuelPort



**Compact Automatic FuelPort**



**Level Transmitter**

## Description

The Simplex Automatic FuelPort is a factory packaged system for control of filling operations of aboveground tanks that are filled from pumper trucks. The Automatic FuelPort provides a ready means of ground level connection of the fill hose, and captures spills that may occur at the fill point during filling operations. The Automatic FuelPort alerts the operator at Tank Full with filling operations locked out at High Level. A leak detection circuit prevents filling of leaking tanks. Visual and audible level and leak alarms and continuous level indication are provided.

The Simplex Automatic Fuel-Port is available for use with fuel oil (Class-II liquids) or gasoline (Class-I liquids).

Single or multiple tank controllers are available. Multiple tank controllers allow operator selection of the tank to be filled with automatic lockout of all other tanks.

## How It Works:

1. Delivery truck arrives and driver proceeds to Automatic FuelPort to make fuel delivery.
2. Connect ground cable
3. Unlock fill box and control box
4. Turn on controller
5. Read fuel level in tank on level indicator gauge
6. Connect delivery hose to hose coupling
7. Open valve on truck
8. Start delivery pump on truck
9. Press Valve Open pushbutton on controller
10. Automatic FuelPort valve opens
11. Fuel is delivered to tank
12. At Tank Full level, audible and visual alarm activates and alerts driver
13. Driver may stop delivery by pressing the Valve Close pushbutton and proceed to step #16
14. Driver tops off to Tank Full



15. At High Level, audible and visual alarm activates and Automatic FuelPort valve closes (valve may not be reopened)
16. Stop fill pump
17. Drain delivery hose
18. Close truck valve
19. Disconnect delivery hose from Automatic FuelPort
20. Turn controller off
21. Close and lock Automatic FuelPort doors
22. Proceed to next delivery, where, hopefully, the owner has had the foresight to install a Simplex Automatic FuelPort

## Includes:

- Freestanding, pad or tank mountable, weatherproof and lockable enclosure
- Quick disconnect hose coupling with dust plug
- Check valve
- Electrically operated shutoff valve
- Automatic controller, described below
- Hand pump for spill containment, with shutoff and check valve
- Ground stud

## Controller

### Includes:

- Level transmitter for installation in 2" tank fitting minimum
- Digital level indicator scaled in percent level (diesel version only)
- Tank Full visual alarm
- High Level visual alarm
- Tank leak alarm
- Audible alarm horn activated by alarms above
- Power available indicator
- Control power On-Off switch
- Valve Open/Close push-buttons
- Type 3R enclosure (fuel oil version)
- Explosion proof enclosure (gasoline version)

### Specifications:

Fitting size: 2", 3" or 4"

Spill containment:

Automatic FuelPort - 20 gallons

Compact Automatic FuelPort - 7 gallons

Hand pump capacity: 1 gpm

Paint: white

Net Weight: 343 lbs. (Oil), 363 lbs.

(Gas)

Control power: 115-1-60v

Level transmitter fitting: 2" min.

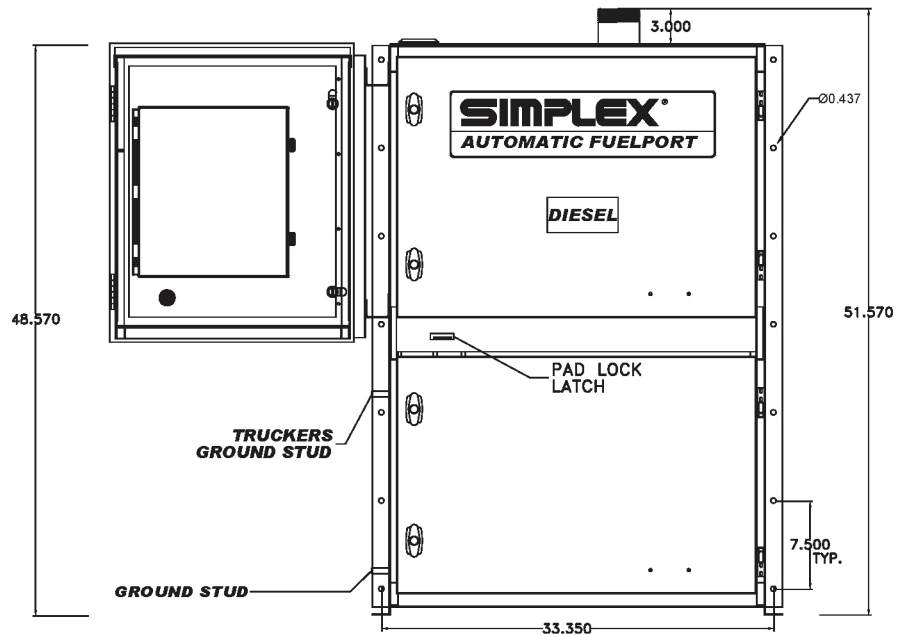
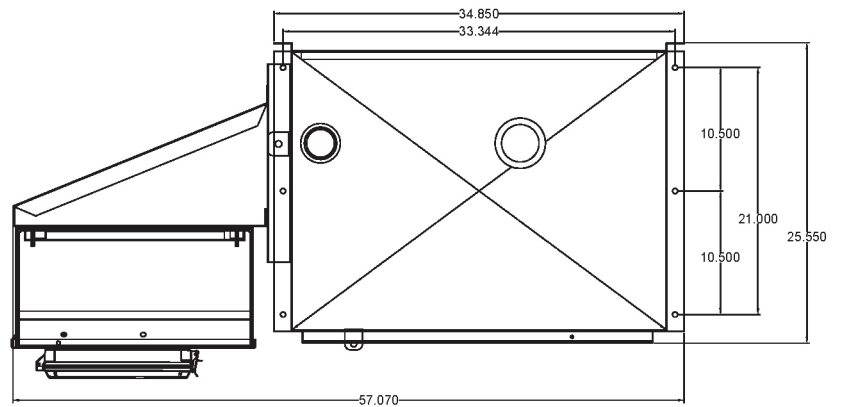

## Automatic FuelPort for Filling Multiple Tanks



### Description

When used for filling of two or more tanks, the Automatic FuelPort allows for operator selection of the tank to be filled with automatic lockout of all off-line tanks. Sophisticated interlocks prevent inadvertent filling of a non-selected tank.

Tank Full alert and High Level automatic shutoff are provided. Tank level indicator and (optional) leak sensing are included.



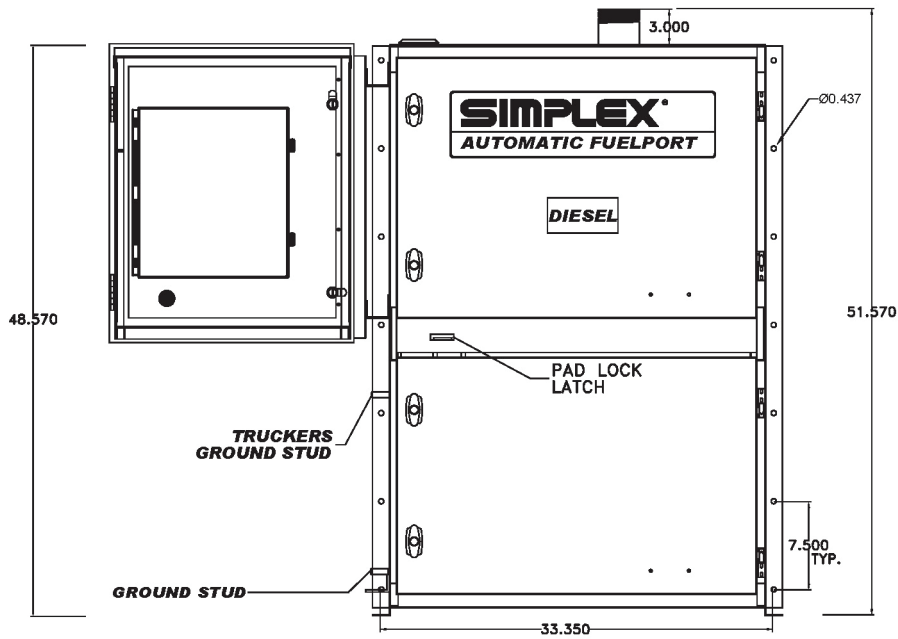
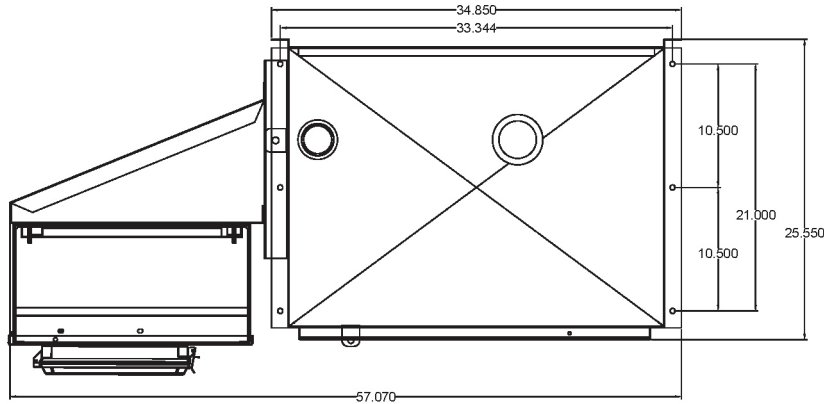

### Automatic FuelPort Order Checklist

- If gasoline use, is vapor recovery required?
- How many tanks to fill?
- Tank leak sensing required?
- Size fill fittings: 2", 3" or 4"?
- Accurate tank dimensions required, 2" or 4" fitting required for transmitter (specify)
- Specify options

## SmartPump

### Description

The Simplex SmartPump is a tank fill pump with intelligence. The SmartPump is a factory packaged system for transfer of fuel from gravity trucks to storage tanks and control of filling operations to prevent overflow and allow for full



**SmartPump with Large Control Box**

draining of the truck delivery hose. The SmartPump provides a ready means of ground level connection of the fill hose, and captures spills that may occur at the fill point during filling operations. The SmartPump includes a high capacity fuel transfer pump and intelligent pump controls. The unique design and intelligence of the SmartPump allows full and easy draining of the truck fill hose prior to disconnect. The SmartPump detects Tank Full level, stops filling operations and activates an alarm. The SmartPump allows the operator to continue filling and/or drain the fill hose up to the High Level at which time all filling operations are locked out and an alarm is activated. A leak detection circuit prevents filling of leaking tanks. Visual and audible level and leak alarms and continuous level indication are provided.

The Simplex SmartPump is available for use with fuel oil (Class-II liquids) or gasoline (Class-I liquids).

Single or multiple tank controllers are available. Multiple tank controllers allow operator selection of the tank to be filled with automatic lockout of all other tanks.

### How It Works:

1. Delivery truck arrives and driver proceeds to SmartPump to make fuel delivery
2. Connect ground cable
3. Unlock fill box and control box
4. Turn on controller
5. Connect delivery hose to hose coupling
6. Open valve on truck
7. Open SmartPump inlet valve
8. Open SmartPump outlet valve
9. Start SmartPump
10. Fuel is delivered to tank
11. At Tank Full level, audible and visual alarm activates and alerts driver, SmartPump stops
12. Driver may stop delivery at this point
13. Driver can restart SmartPump by pressing the Override pushbutton and pressing the Pump Start pushbutton. Pump will run for 30 second intervals
14. Driver can continue filling or drain delivery hose at this time
15. To drain hose, driver closes truck valve and breaks hose connection at tank and allows SmartPump to empty hose
16. Driver may restart SmartPump in 30 second intervals, but all filling and hose draining operations must be ended and truck valve closed prior to reaching High Level
17. At High Level, audible and visual alarm activates and SmartPump stops. SmartPump can not be restarted
18. Close SmartPump outlet valve
19. Close SmartPump inlet valve
20. Disconnect delivery hose and ground cable
21. Turn controller off
22. Close and lock SmartPump doors
23. Proceed to next delivery, where, hopefully, the owner has had the foresight to install a Simplex SmartPump

### Specifications:

Fitting size: 2", 3" or 4"  
 Spill containment: 7 gallons  
 Paint: white  
 Net weight: 617 lbs. (Oil), 632 lbs. (Gas)  
 High level floatset: 2"

### Includes:

- Freestanding, pad mountable, open construction pumpset with weatherproof and lockable fill box with 7 gallon spill containment sump and weatherproof and lockable control box
- 2", 3" or 4" fittings available
- Quick disconnect hose coupling with dust plug
- Inlet shutoff valve
- Check valve
- Outlet shutoff valve
- Line purging valve
- Spill sump drain valve
- High capacity transfer pump, see details below
- Automatic controller, described below
- Ground stud

### Controller Includes:

- High level floatset for installation in 2" tank fitting minimum
- Tank Full visual alarm
- High Level visual alarm
- Tank Leak alarm
- Audible alarm horn activated by alarms above
- Power Available indicator
- Control Power On-Off switch
- Pump Start/Stop push-buttons
- Top-off/hose drain mode push-button
- Pump starter
- Type 3R control enclosure (fuel oil version)
- Type 7 explosion proof control enclosure (gasoline version)

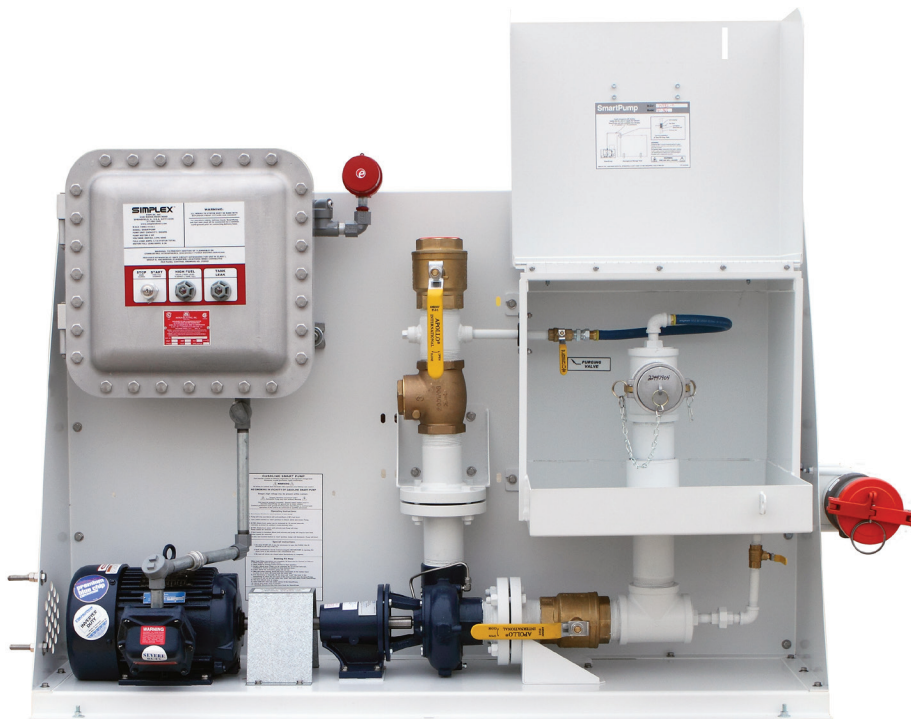

**Gas SmartPump with Vapor Recovery**

### PUMP PERFORMANCE

SmartPump	Head (ft.)	Gpm	SmartPump	Head (ft.)	Gpm
with 5 hp pump, 3" or 4" inlet:	75	200	SmartPump with 2 hp pump, 2" inlet:	55	75
	65	250		45	125
	55	300		35	150
	40	350		15	200
	25	400			

### SmartPump Order Checklist

- If gasoline use, is vapor recovery required?
- How many tanks to fill?
- 2 hp (150 gpm) or 5 hp (300 gpm) SmartPump?
- Specify voltage: single phase: 120v or 240v; 3 phase: 208, 240, 416, 480v
- If 5 hp, 3" or 4" inlet?
- Tank leak sensing required?
- Accurate tank dimensions required, 2" or 4" fitting required for transmitter (specify)
- Specify options

## Single-Tank SmartPumps

Includes level transmitter shipped loose for remote tank mounting

MODEL NO.	APPLICATION**	FITTINGS	HP/GPM
SP-2.....	Oil.....	2".....	2/150
SP-2G.....	Gas.....	2".....	2/150
SP-3.....	Oil.....	3".....	5/300
SP-3G.....	Gas.....	3".....	5/300***
SP-3GV.....	Gas, with vapor recovery.....	3".....	5/300***
SP-4*.....	Oil.....	4".....	5/300
SP-4G*.....	Gas.....	4".....	5/300***
SP-4GV*.....	Gas, with vapor recovery.....	4".....	5/300***

\*4" inlet, 3" internals and outlet

\*\*APPLICATION: "Oil" = Class II liquid, flash point > 100° F  
 "Gas" = Class I liquid, flash point < 100° F

\*\*\*SP-3, SP-4 Gasoline (or Explosion-Proof) SmartPumps rated at 5 hp, 300 gpm must be 3-phase voltage. If only single phase is available at job site then a SP-2 at 2 hp, 150 gpm can be used. However, Simplex can install a larger inlet coupling as required.

## SmartPump Options:

### Inlet Fittings:

- Standard quick disconnect coupling: 2", 3" or 4":
  - 2" available for 2 hp SmartPump
  - 3" and 4" available for 5 hp SmartPump
- Dry disconnect adaptor: 2" or 3":
  - 2" available for 2 hp SmartPump
  - 3" available for 5 hp SmartPump

### Valves:

- Fusible link fire valve, installed on outlet
- Fire rated shutoff valves, in lieu of standard bronze valves
- Fire rated shutoff valve assembly for installation on aboveground storage tank fuel inlet, including fire rated ball valve and self-closing fusible link valve (shipped loose)

### Leak Sensors:

- Tank leak sensor, float switch type, for mounting in a vertical position in collection sumps, monitoring pipes and steel double wall tank sumps. For installation in 2" fitting. SmartPump controller includes: tank leak alarm, tank fill shutoff, alarm contacts.
- Tank leak sensor, as above, except optical type, for restricted space installation in tank annular space, double wall pipe collection sump, etc.
- Tank lead sensor, floatswitch type, adjustable on cord with cinch-lock fitting

## Two-Tank SmartPumps

Includes two level transmitters and two electrically operated shutoff valves shipped loose for remote tank mounting.

MODEL NO.	APPLICATION**	FITTINGS	HP/GPM
SP-2/2.....	Oil.....	2".....	2/150
SP-2G/2.....	Gas.....	2".....	2/150
SP-3/2.....	Oil.....	3".....	5/300
SP-3G/2.....	Gas.....	3".....	5/300***
SP-3GV/2.....	Gas, w/vapor rec.....	3".....	5/300***
SP-4/2*.....	Oil.....	4".....	5/300
SP-4G/2*.....	Gas.....	4".....	5/300***
SP-4GV/2*.....	Gas, w/vapor rec.....	4".....	5/300***

\*4" inlet, 3" internals and outlet

\*\*APPLICATION: "Oil" = Class II liquid, flash point > 100° F  
 "Gas" = Class I liquid, flash point < 100° F

\*\*\*SP-3, SP-4 Gasoline (or Explosion-Proof) SmartPumps rated at 5 hp, 300 gpm must be 3-phase voltage. If only single phase is available at job site then a SP-2 at 2 hp, 150 gpm can be used. However, Simplex can install a larger inlet coupling as required.

## Multiple Tank SmartPumps

Two or more tanks: includes level transmitters, and electrically operated shutoff valves for remote tank mounting (one set for each tank) and a thermal expansion pressure relief valve (one for each system) shipped loose. Change model number suffix to indicate number of tanks.

## SmartPump Options cont'd:

### Indicator Gauges:

- Digital level indicator, percent level reading. Includes level transmitter for installation in 2" NPT fitting
- Digital tank monitor with display of tank level in gallons, liters or percent; high and low level alarms, audible alarm; output contact. Includes level transmitter for installation in 2" NPT fitting

- Hydrostatic level gauge, hand pump type with 5" dial type indicator calibrated in gallons. Transmitter installed in 2" tank fitting

### Enclosures:

- Lockable full enclosure with containment basin and hand pump
- Stainless steel cabinet construction for corrosive or coastal environments is also available

## SmartPump

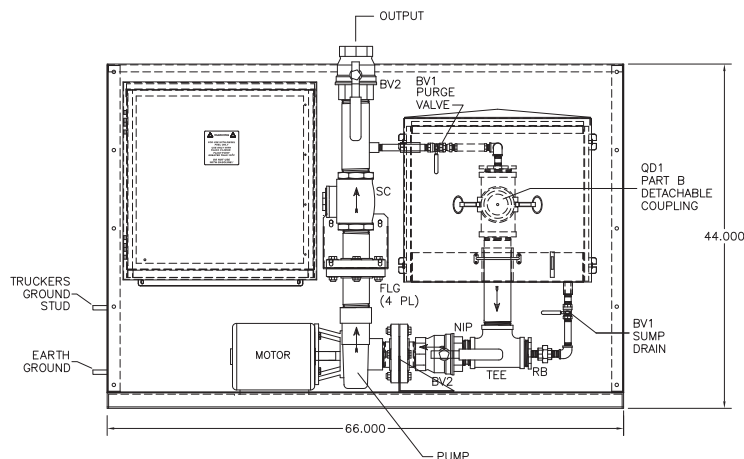

## Gas SmartPump

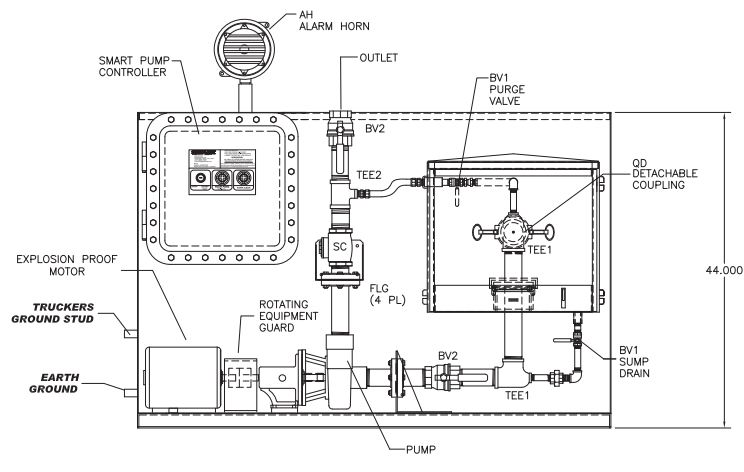

## SmartPump with Lockable Enclosure

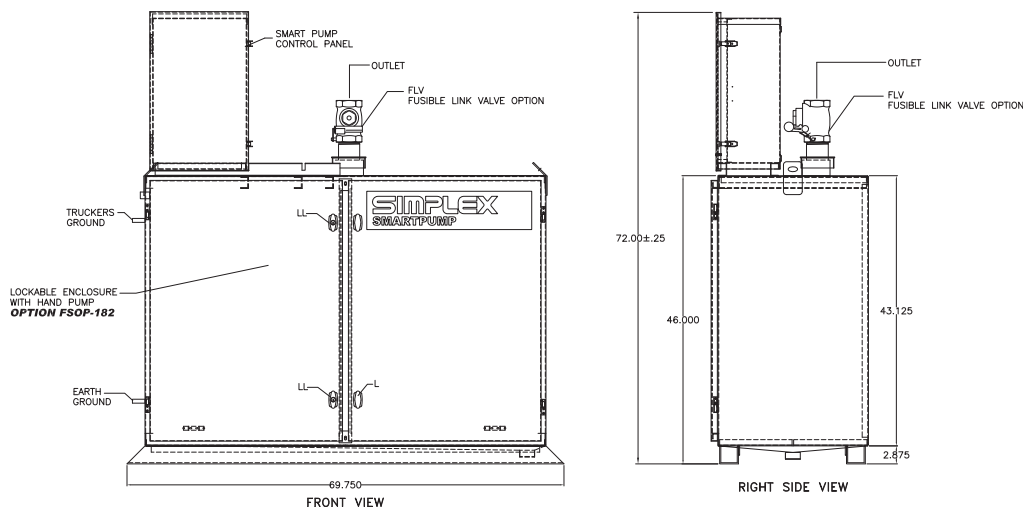

## Mini SmartPump

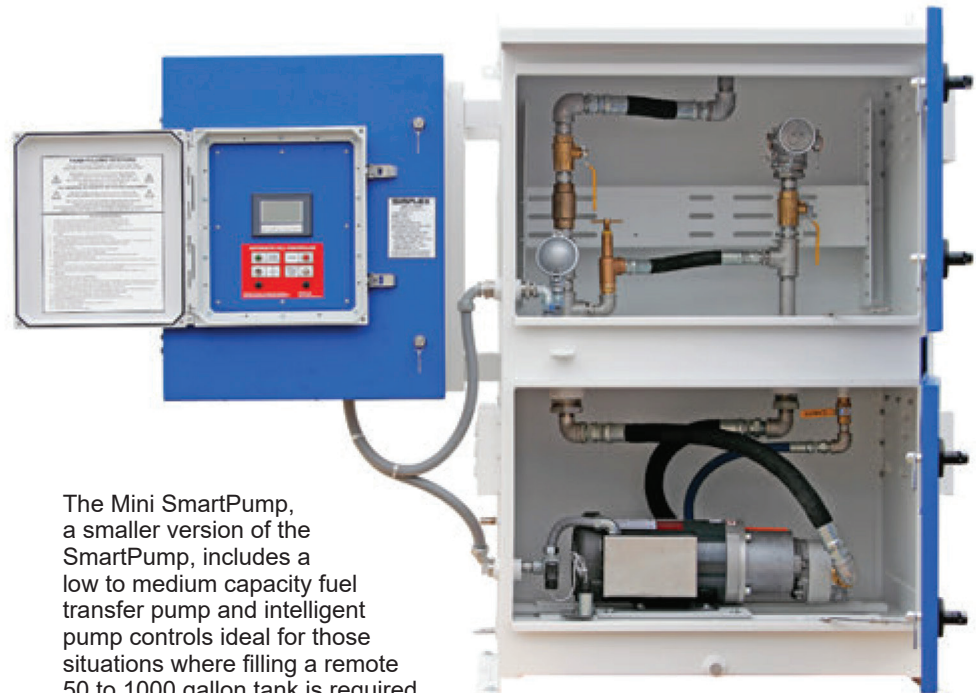

The Mini SmartPump, a smaller version of the SmartPump, includes a low to medium capacity fuel transfer pump and intelligent pump controls ideal for those situations where filling a remote 50 to 1000 gallon tank is required. The Mini SmartPump offers control of filling operations to prevent overfill and to allow for fuel draining of the truck delivery hose. The Mini SmartPump provides a ready means of ground level connection of the fuel hose and captures spills that may occur at the fill point during filling operation. Features include:

- Freestanding, pad mountable, fully enclosed cabinet construction with weatherproof and lockable fill connection and control boxes, 20 gallon spill containment sump
- 2", 3", or 4" fittings available
- Quick disconnect hose coupling with dust plug (dry break type are also available)
- Inlet shutoff valve
- Check valve
- Outlet shutoff valve
- Pump flow sensor for timed delay auto-shutoff
- Sump drain valve for sump to pump emptying
- Positive displacement transfer pump available in 2, 7, 10, 17 or 25 GPM
- Automatic controller
- Ground stud

### Voltages

- 115-240v, 1-phase, 60 Hz
- 230-460v, 3-phase, 60 Hz

### Controller Includes

- Level transmitter for installation in 2" tank fitting
- Tank Full visual alarm
- High Fuel visual alarm
- Tank Leak visual alarm
- Audible alarm horn activated by alarms above
- Pump Loss of Flow sensor/alarm
- Power Available indicator
- Control Power On-Off switch
- Pump Start/Stop pushbuttons
- Top-off/hose drain mode pushbutton
- Pump Starter
- Type 3R control enclosure

### Specifications:

Fitting size: 2", 3" or 4"  
Application: Oil  
Dimensions: 53" x 30" x 58"  
Shipping weight: 425 lbs.

*Oil = Class II liquid, flash point > 100° F  
Consult Simplex for gasoline application.*

## AFC Automatic Fill Controller

The Simplex AFC - Automatic Fill Controller is an electronic monitor and control system used to control tank filling and prevent overflow. The AFC is used with a remote electric solenoid valve or motorized valve.

During filling operations, the AFC provides continuous level indication, Tank Full level audible and visual alarm, High Fuel level audible and visual alarm and shut-off.

The AFC can receive a signal from an external tank leak sensor to activate an alarm, send a remote signal and automatically close the fill valve.

### AFC Includes

- Type-3R rainproof, lockable enclosure with hinged door
- Electronic level sensor for installation in tank - 2" fittings
- Digital percent level indicator
- High visibility red alarm light, High Fuel
- High visibility amber alarm light; Tank Full
- 90dB audible alarm horn with silence pushbutton
- Control Power switch
- Fill Valve Open and Close pushbuttons
- Alarm Tank Full level
- Alarm and automatic valve shut-off at High Fuel level
- Leak sensor input/alarm, automatic shut-off
- Indicators:
  - High Fuel
  - Tank Full
  - Control Power Available
  - Fill Valve Open
  - Fill Valve Closed
  - Tank Leak

### Specifications

Power supply: 115V AC, 1 $\phi$ , 60 Hz  
 Accuracy:  $\pm$  2%  
 Transmitter fitting: 2" NPT or greater

## TC8 Tank Alarm Panel

The Simplex Tank Commander TC8 Tank Alarm Panel is used to monitor High Level, Low Level, and Tank Leak Alarms. The TC8 provides both audio and visual indication. Relay dry contacts are provided for remote alarms. The TC8 receives signals from float switches mounted on the tank. The float switches may be included as an option or provided by others.

The TC8 is available in 115VAC and 24VDC voltages. The TC8 is for use with fuel oil or other Class II liquids or non-flammable liquids or chemicals. The TC8 carries a UL 508A Label.

### Includes

- Type 3R, lockable enclosure with hinged door
- UL 508A Label
- Alarm light; high level
- Alarm light; low level
- Alarm light; tank leak
- Alarm horn with silence pushbutton
- Press-To-Test pushbutton
- Press-To-Reset pushbutton
- Indicators for
  - Tank leak (dry contact)
  - High Fuel alarm (dry contact)
  - Low Fuel alarm (dry contact)
- Level sensors, optional

### Specifications

Power supply:  
 115VAC, 1 $\phi$ , 60 Hz or 24VDC  
 Application:  
 Fuel oil or other Class II liquids or non-flammable liquids or chemicals  
 Alarm contacts:  
 10A @125/250VAC, 30VDC

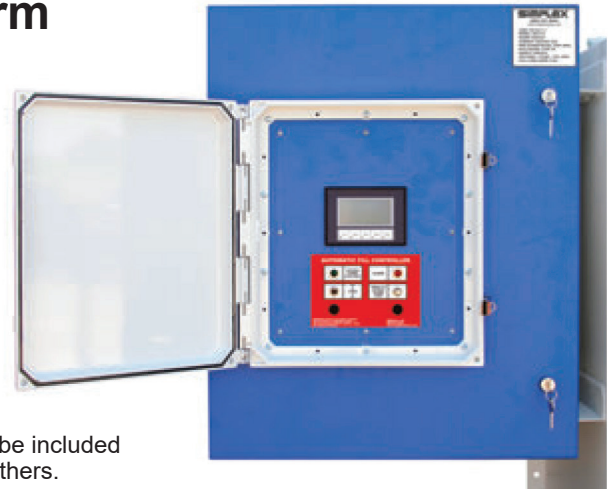

**AFC - Automatic Fill Control Panel**

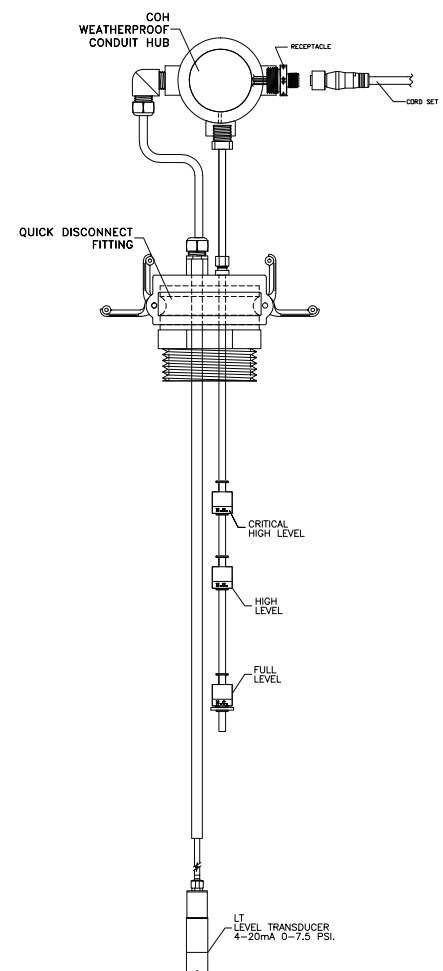

**Level Transmitter**

## QUOTE REQUEST

Visit the Simplex web site at [www.simplexdirect.com](http://www.simplexdirect.com) to request a quote.

For Automatic FuelPorts and SmartPumps fill out the sheet below from the download page for that model and attach it to your quote request.

F411 Rev. 2 © Simplex 2020

**Tank Data Form**

Customer: \_\_\_\_\_ Project: \_\_\_\_\_ Date: \_\_\_\_\_

P.O #: \_\_\_\_\_ S.O# \_\_\_\_\_ Job #: \_\_\_\_\_

Product Used:	Tank Construction:	Tank Shape:
<input type="checkbox"/> Diesel	<input type="checkbox"/> AST	<input type="checkbox"/> Rectangular: L _____ W _____ H _____
<input type="checkbox"/> Gas	<input type="checkbox"/> UST	<input type="checkbox"/> Horizontal Cylinder: D _____ L _____
<input type="checkbox"/> Other: _____	<input type="checkbox"/> Single Wall	<input type="checkbox"/> Vertical Cylinder: D: _____ H _____
	<input type="checkbox"/> Double Wall	
	<input type="checkbox"/> Vaulted	
	<input type="checkbox"/> Base tank	

Comments:

Capacity (actual gal.): \_\_\_\_\_ Number of Tanks: \_\_\_\_\_

**Tank Specifications - Reference Tank Sketch**

H - Tank Inside Height/Diameter \_\_\_\_\_

D - Double Wall Tank Interstitial Space \_\_\_\_\_

R - Fitting Riser \_\_\_\_\_

F - Transmitter Mounting Port Style, Size and Qty.

**Tanks under 30" require (2) 2" ports or (1) 4" port at minimum**

a)  Female  Male

b)  2" NPT  4" NPT

Other: \_\_\_\_\_

c) Quantity: \_\_\_\_\_

L - Leak Sensor Mounting Port Style and Size:

a)  Female  Male

b)  2"NPT  Other: \_\_\_\_\_

M - Leak Sensor Well Depth: \_\_\_\_\_

**Tank Sketch**