

Description

Simplex MicroStar Precision Air Heaters (Load Banks) enable comprehensive testing of data center hot aisle/cold aisle cooling systems. The MicroStar is a 19-inch rack mountable device (10U high) that can be easily installed into a wide range of standard server racks. Precision heat generation is possible via the integration of adjustable heat levels (load steps) and adjustable airflow (velocity and CFM). The MicroStar is designed and manufactured by Simplex, the leading manufacturer of data center load banks and OEM Generator Production Test Cells.

The MicroStar is rated up to 17.5kw at 240vAC, single-phase, and connects to the rack power distribution bus via standard C19 plugs.

Weighing only 45 pounds, the Microstar can be easily rack mounted by a single person. With its exclusive quarter-turn, key-lockable mounting tabs, the Microstar can be installed in any standard rack, including square-hole rails, non-threaded round hole or threaded hole (#10, #12, M6) rails.

The MicroStar Precision Heater features six (6) independent heater circuits, each powered from a plug/power inlet. A Master Control function allows simultaneous on-off control of all selected circuits, as well as remote master on/off control, via a 24vDC input.

The single 10-inch cooling fan has a solid-state variable speed control with safety override to allow precision adjustment of heat rejection/temperature rise/airflow. An AC current sensor functions to automatically switch the cooling fan to a higher rate in the event of operator selection of low airflow versus high heat.



Design Features

- Precision thermal control of heat load, temp rise and airflow via step control and fan speed control
- Standard unit can be installed in any standard server rack
- Exclusive quarter-turn, key lockable mounting tabs
- Light weight (45 pounds)
- Automatic overload protection: fan reverts to higher speed above a preset power level
- Over temperature sensor with master disconnect and alarm
- Internal fuse protection of heat circuits
- Master control of all steps
- Remote master control input (24v)
- All 24vDC control circuits via internal power supply
- An industrial-duty product by Simplex, the leading manufacturer of load banks

Buy or Rent

- Available to purchase or rent at Simplex, Inc.

- Intertek ETL Listed (Canada & USA)
- 

MicroStar R

Precision Air Heater (Load Bank)

for Hot Aisle/Cold Aisle Testing of Data Center Cooling Systems • Page 2

SIMPLEX®

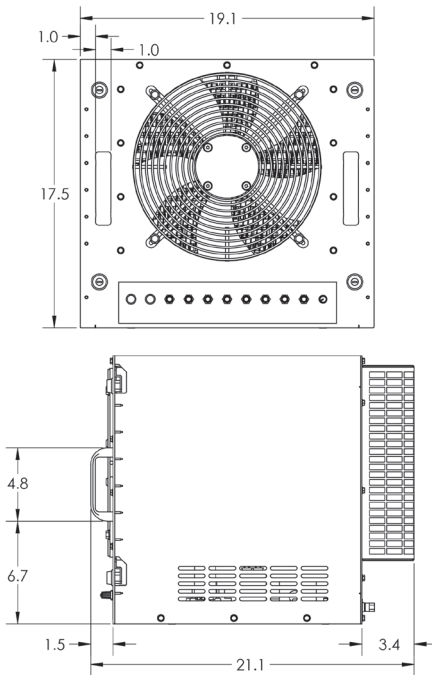

Rentals supplied packaged in one, two, and three unit cases.

Ratings

240vAC, 1-ph	Capacity		Max Amps at 240v
	230vAC, 1-ph	208vAC, 1-ph	
17.5kw	16.1kw	13.15kw	74a

Thermal Steps

Section 1*	1.50kw	1.38kw	1.13kw	13.4a
	1.50kw	1.38kw	1.13kw	
Section 2	2.5kw	2.3kw	1.88kw	10.4a
Section 3	2.5kw	2.3kw	1.88kw	10.4a
Section 4	2.5kw	2.3kw	1.88kw	10.4a
Section 5	3.5kw	3.21kw	2.63kw	14.58a
Section 6	3.5kw	3.21kw	2.63kw	14.58a

*Section 1 includes .9A control/fan load

Airflow

MicroStar: Solid-state speed control, 400-1520 cfm

Connection

Each section above connected via C19 power inlet/plug

Control

24vDC control via internal power supply

Unit face mounted controls:

- Master on-off switch, controls all selected steps, as noted above
- Individual step switches, rated as noted above
- Fan speed control dial
- Fan speed control and high power override (selects higher fan speed above a preset thermal level (ampere level))
- "On" green LED
- "Overtemperature" red LED (with master control disconnect)

Dimensions and Mounting

Height	10U (17.5 inches)
Width	Fits 19-inch server rack
Depth	19 inches
Weight	45 pounds
Mounting	Quarter-turn, key lockable tabs Adaptor pins for square hole, non-threaded round hole and threaded round hole (#10, #12, M6)