



Packaged Pump Sets
FOR DIESEL FUEL OIL APPLICATION

SIMPLEX[®]

Description

Simplex **SPS Series Packaged Pump Sets** are pre-engineered, integrated systems of pumps, pump drivers, controls and accessories, pre-plumbed and pre-wired, totally contained within an enclosure equipped with a leak detection basin. External ports are provided for connection of field plumbing. Four models are available spanning from 2 GPM through 36 GPM, simplex, duplex, triplex or quadplex pumps; 0.33 through 7.5 HP and are suitable for wall or pad mounting. Isolated compartments are provided for mechanical and electrical devices. Full system integration of pumps, starters, controls, tank monitors, tank level controls, external alarm panels is provided.

If requirements exceed the capacity of an SPS enclosure, pump sets can be specified skid-mounted. Simplex **SKS Series Skid Pump Sets** offer the customer a greater variety and quantity of options but because of the open catch basin design they are suitable for indoor installation only.

Simplex Packaged Pump Sets are intended for use with fuel oil or lube oil.

Features

- System engineered, integrated function packages
- TYPE 1 indoor enclosure, primed and painted
- TYPE 3R weatherproof enclosure, primed and painted, available
- Wall or pad mountable
- Segregated electrical/mechanical compartments within enclosure
- Enclosure drip pan and leak detector
- Pressure relief valve, external port for relief to tank available
- Pump disconnect circuit upon leak detection
- Inlet, outlet and pressure relief manifolds (SPS Series only)
- Fuel connections made to fittings in sidewalls (SPS Series only)
- High performance hydraulic gear pumps
- Pump shutoffs available
- Industrial motors
- Motor starter with overload relay and disconnect available
- Disconnect switch interlocked with hinged door
- Simplex, duplex, triplex, quadplex pumps available
- Automatic duplex pump controllers available
- "Tank Commander" tank monitors, PLC Control, level controllers, annunciators, fill panels, overfill panels are available as options
- Packaged Pump Sets can be engineered with Simplex Main Storage Tanks, Day Tanks and Fuel Supply Systems

MODEL	SINGLE	DUPLEX	TRIPLEX	QUADPLEX
SPS-25	25GPM-1½HP	10GPM-¾HP	2GPM-½HP	N/A
SPS-55	35GPM-5HP	17GPM-1HP	7GPM-1HP	2GPM-½HP

Application Guide



CHOOSING A PUMP

Super-XL Pump

for applications where the pump starts and stops on demand, such as for automatic tank refilling. Use for viscosity to 1000 SSU. Use also for high pressure applications up to 2500 PSI. Do not use for noise sensitive applications.

Series 420 & 500 Pumps

(cast iron gear) for continuous duty applications where the pump runs nonstop for extended periods of time. Use for boiler feed loop applications. Use also for noise sensitive applications. Viscosity from 32 to 5000 SSU or higher with slow speed motor.

CHOOSING A MODEL

SPS-25

complex single pump applications involving starters and level controllers

– or –

simple duplex and triplex pump applications involving starters and duplex controller

SPS-55

complex and large, single pump applications involving starters and level controls

– or –

complex duplex, triplex, quadplex pump applications involving starters and controllers

SKS

size and complexity is dependent on available site space, rated TYPE 1 indoor



SPS-25-SD Mechanical Compartment

WARNING: These Pump Sets are not intended for use with gasoline or other flammable liquids having a flash point less than 100°F. Use with gasoline or use with any flammable liquids at a temperature exceeding the flash point of that liquid, presents an immediate explosion and fire hazard. Do not use the Pump Set at a temperature exceeding the flash point of its contents.

Standard Equipment List

NOTE: All Standard Pump Sets include Super-XL 2GPM, 1/3HP, 115V AC pumps and containment sump with leak sensor. Optional pumps and motors are available. Consult Simplex for cabinet size when multiple options are required.

		SPS-25	SPS-55
SINGLE	Basic (-BS)	X	X
	Super (-SS)	X	X
DUPLEX	Basic (-BD)	X	X
	Super (-SD)	X	X
	Engineer Specifications (-ED)		X

SINGLE PUMP

Basic (-BS)

- Super-XL 2GPM, 1/3HP, 115V AC pump
- Opt. 191, containment sump leak sensor

Super (-SS)

- Super-XL 2GPM, 1/3HP, 115V AC pump
- Opt. 260, door mounted disconnect switch with interlock
- Opt. 768, single-phase starter with coil wired to terminal block
- Opt. 087, shut-off valves on inlet and outlet
- Opt. 095, pressure relief valve
- Opt. 070, check valve
- Opt. 191, containment sump leak sensor

DUPLEX PUMP

Basic (-BD)

- Super-XL 2GPM, 1/3HP, 115V AC pump
- Opt. 345, automatic duplex pump controller
- Opt. 070, check valve
- Opt. 087, shut-off valves on inlet and outlet
- Opt. 191, containment sump leak sensor

Super (-SD)

- Super-XL 2GPM, 1/3HP, 115V AC pump
- Opt. 345, automatic duplex pump controller
- Opt. 070, check valve
- Opt. 260, door mounted disconnect switch with interlock
- Opt. 768, single-phase starter
- Opt. 087, shut-off valves on inlet and outlet
- Opt. 095, pressure relief valve
- Opt. 191, containment sump leak sensor

Engineer Specifications (-ED)

- Super-XL 2GPM, 1/3HP, 115V AC pump
- Opt. 345, automatic duplex pump controller
- Opt. 070, check valve
- Opt. 260, door mounted disconnect switch with interlock
- Opt. 768, single-phase starter
- Opt. 087, shut-off valves on inlet and outlet
- Opt. 095, pressure relief valve
- Opt. 060, fuel strainer
- Opt. 100, pressure gauge with isolation hand valve, each pump outlet
- Opt. 101, vacuum gauge with isolation hand valve, each pump inlet
- Opt. 285, loss of flow alarm/lag pump activate
- Opt. 191, containment sump leak sensor

Description

The Simplex SUPER-XL is a high-technology hydraulic pump featuring pressure-loaded, self-compensating gears and a mechanical shaft seal. The SUPER-XL is the standard pump used in Simplex Packaged Pump Sets and is available in 2-25 GPM capacity range.

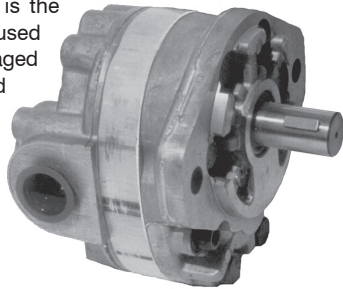

Features

- Pressure loaded design
- Efficient, simple design with few moving parts
- Exceptionally compact and lightweight for their capacity
- Efficient at high pressure operation
- Resistant to cavitation effects
- High tolerance to system contamination
- Reliable under cold weather operation
- Sleeve bearing construction
- Multi-Fluid compatibility

SUPER-XL Pumps

PUMP MODEL	DISPLACEMENT IN³ (CC/REV.)	RPM	Flow, GPM (LPM)				
			100 PSI (6.9 Bar)	1000 PSI (69 Bar)	1500 PSI (103 Bar)	2000 PSI (138 Bar)	2500 PSI (172 Bar)
SUPER XL-11	.262 (4.29)	1800	1.99 (7.54)	1.86 (7.05)	1.79 (6.78)	1.73 (6.56)	1.66 (6.29)
SUPER XL-39	.942 (15.44)	1800	7.08 (26.83)	6.87 (26.04)	6.77 (25.66)	6.66 (25.24)	6.56 (24.86)
SUPER XL-62	1.47 (24.14)	1800	11.10 (42.07)	10.81 (40.97)	10.70 (40.55)	10.60 (40.17)	10.40 (39.42)
SUPER XL-90	2.23 (36.5)	1800	16.70 (63.29)	16.50 (62.54)	16.30 (61.78)		
SUPER XL-114	3.35 (54.9)	1800	25.30 (95.89)	24.90 (94.37)	24.60 (93.23)	24.40 (92.48)	

Simplex Series 420 & 500 internal gear rotary pumps are used for lubricating, low pressure hydraulic, transfer, circulating, burner oil and many other industrial pump applications.

Precisely machined and assembled with only two moving parts, they achieve and retain their reliability over a wider range of viscosities than alternative pump designs. And they're substantially quieter than other pump designs.

All rotors are precision milled and ground. All models have bushing support provided for the rotor shaft for added reliability. Pumps are

equipped with a mechanical seal. With optional seals available in a number of different materials, these pumps can meet almost any temperature or fluid compatibility requirement.

A wide range of configurations with capabilities from 1.8GPM to 35GPM is available.

There are only two moving parts. Pumping action is based on a rotor, idler gear and crescent-shaped partition cast integral with the cover. Optional automatic reversing is available.

Models 420, 422, and 424 are UL Listed.

Series 420 & 500 Pumps

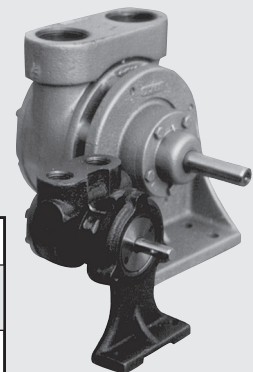

MATERIALS OF CONSTRUCTION					
HOUSING	COVER	ROTOR	IDLER	IDLER PIN	SEAL
CAST IRON	CAST IRON	STEEL	IRON	HARDENED STEEL	MECHANICAL CARBON RING NI-RESIST OR CERAMIC SEAL

Dimensions and Key Features

SPS-25

1. Main Disconnect Switch
2. Ball Valve (4), Opt. 087
3. Check Valve (2), Opt. 070
4. Fuel Line Leak Sensor
5. Sump Drain Plug
6. Pump (2)
7. Motor (2)
8. Drip Pan
9. Fuel Strainer (2), Opt. 060
10. Junction Box
11. Mounting Holes (6), .437" x .875" Dia.
12. Pump Outlet, 1" NPT Male
13. Pressure Relief Outlet, 1" NPT Male
14. Pump Inlet, 1" NPT Male
15. Wall Mounting Holes (14), .437" x .875" Dia.
16. Lockable Latch (2)
17. Customer Conduit Entry, 1½" and 1" NPT, both sides
18. Vent Louvers, both sides

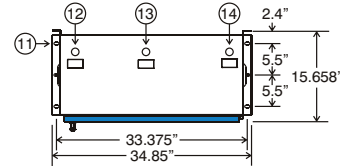

TOP VIEW WITHOUT CONTROL PANEL

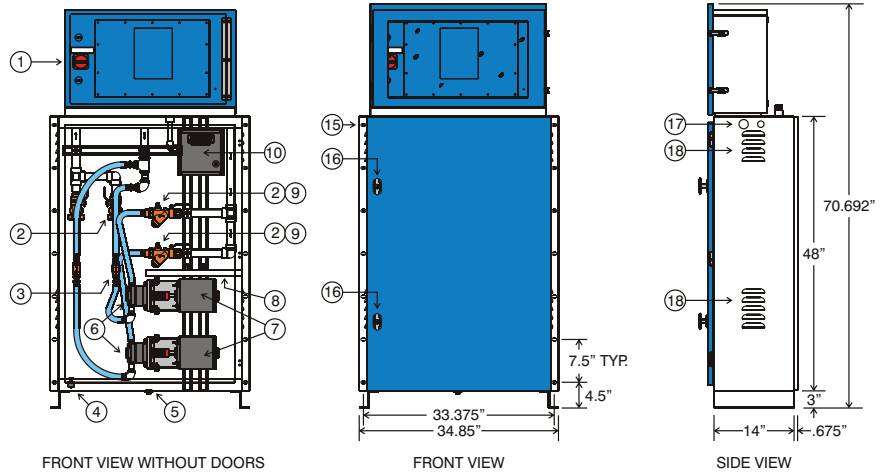

FRONT VIEW WITHOUT DOORS

FRONT VIEW

SIDE VIEW

SPS-55

1. Mounting Holes (12), .437" x .875" Dia.
2. Pump Outlet, 1" NPT
3. Pressure Relief Outlet, 1" NPT
4. Pump Inlet, 1.5" NPT
5. Weatherproof Outer Door, Opt. 181
6. Wall Mounting Holes (14) - .437" x .875" Dia.
7. Ball Valve (3), Opt. 087
8. Check Valve - Opt. 070
9. Fuel Strainer, Opt. 060
10. Junction Box
11. Pressure Relief Valve, Opt. 095
12. Pump (2)
13. Motor (2)
14. Sump Drain Plug
15. Fuel Line Leak Sensor
16. Fuel Strainer (2), Opt. 060
17. Drip Pan
18. Vent Louvers, both sides
19. Lockable Latch
20. Latch (3)

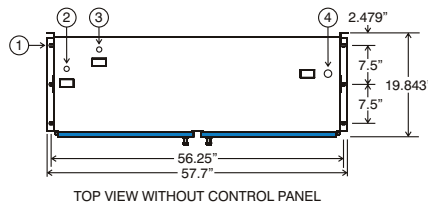

TOP VIEW WITHOUT CONTROL PANEL

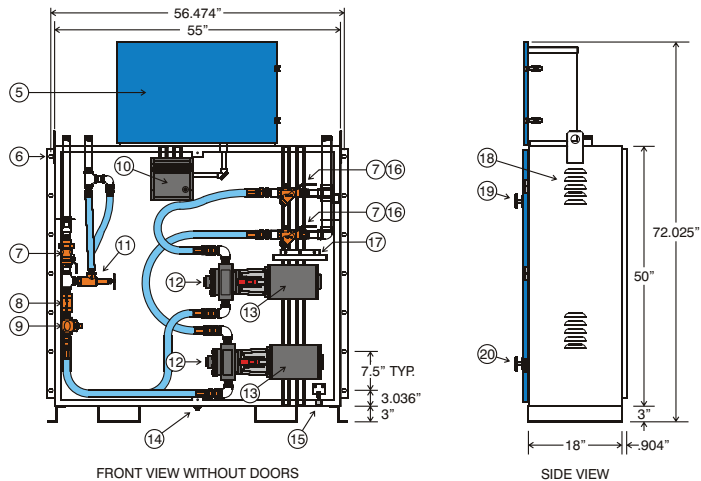

FRONT VIEW WITHOUT DOORS

SIDE VIEW

SKS-10

1. Mounting Holes (4), 3/4"
2. Motor
3. Pump
4. Pump Outlet, Ball Valve, 3/4" NPT
5. Pump Inlet, Ball Valve, 3/4" NPT
6. Sump Drain, Both Sides (2), 1/2" NPT
7. Fuel Line Leak Sensor

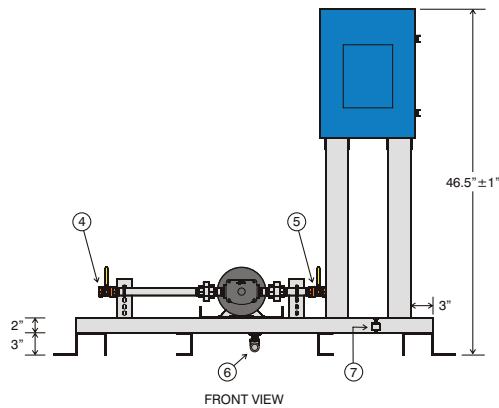
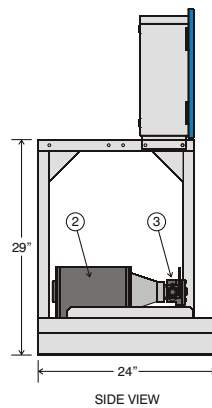
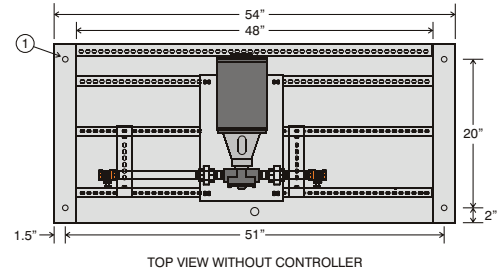

SKS-30

1. Mounting Holes (4), 3/4"
2. Pressure Relief Outlet, 3/4" NPT Male
3. Motor (2)
4. Pump (2)
5. Ball Valve (4), Opt. 087
6. Fuel Strainer (2), Opt. 060
7. Auxiliary Inlet, 1" NPT
8. Pump Unit Outlet, 1" NPTM
9. Check Valve (2), Opt. 070
10. Flowswitch (2), Opt. 285
11. Sump Drain, Both Sides (2), 1/2" NPT
12. Fuel Line Leak Sensor
13. Pump Unit Inlet, 1" NPT

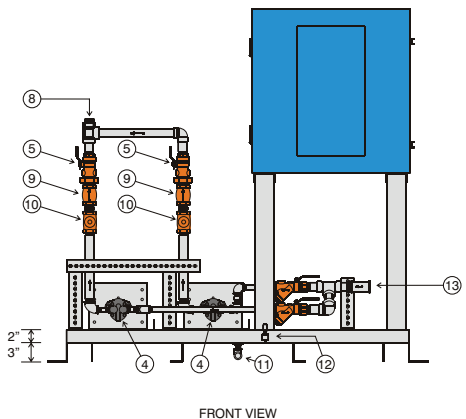
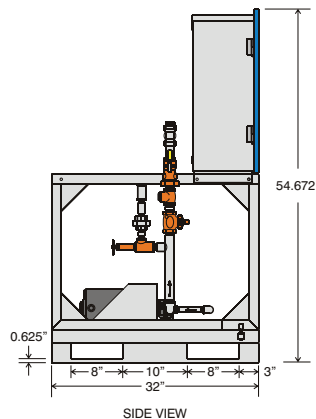
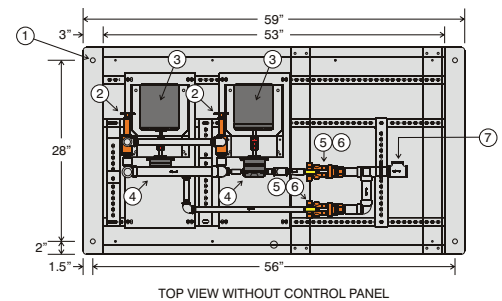

SKS-50

1. Mounting Holes (4), 3/4"
2. Pressure Relief Outlet, 3/4" NPT Male
3. Motor (2)
4. Pump (2)
5. Ball Valve (4), Opt. 087
6. Fuel Strainer (2), Opt. 060
7. Pump Inlet, 3" NPT
8. Pump Unit Outlet, 2" NPT
9. Flowswitch (2), Opt. 285
10. Check Valve (2), Opt. 070
11. Sump Drain, Both Sides (2), 1/2" NPT
12. Fuel Line Leak Sensor
13. Main Disconnect Switch, Opt. 260

